

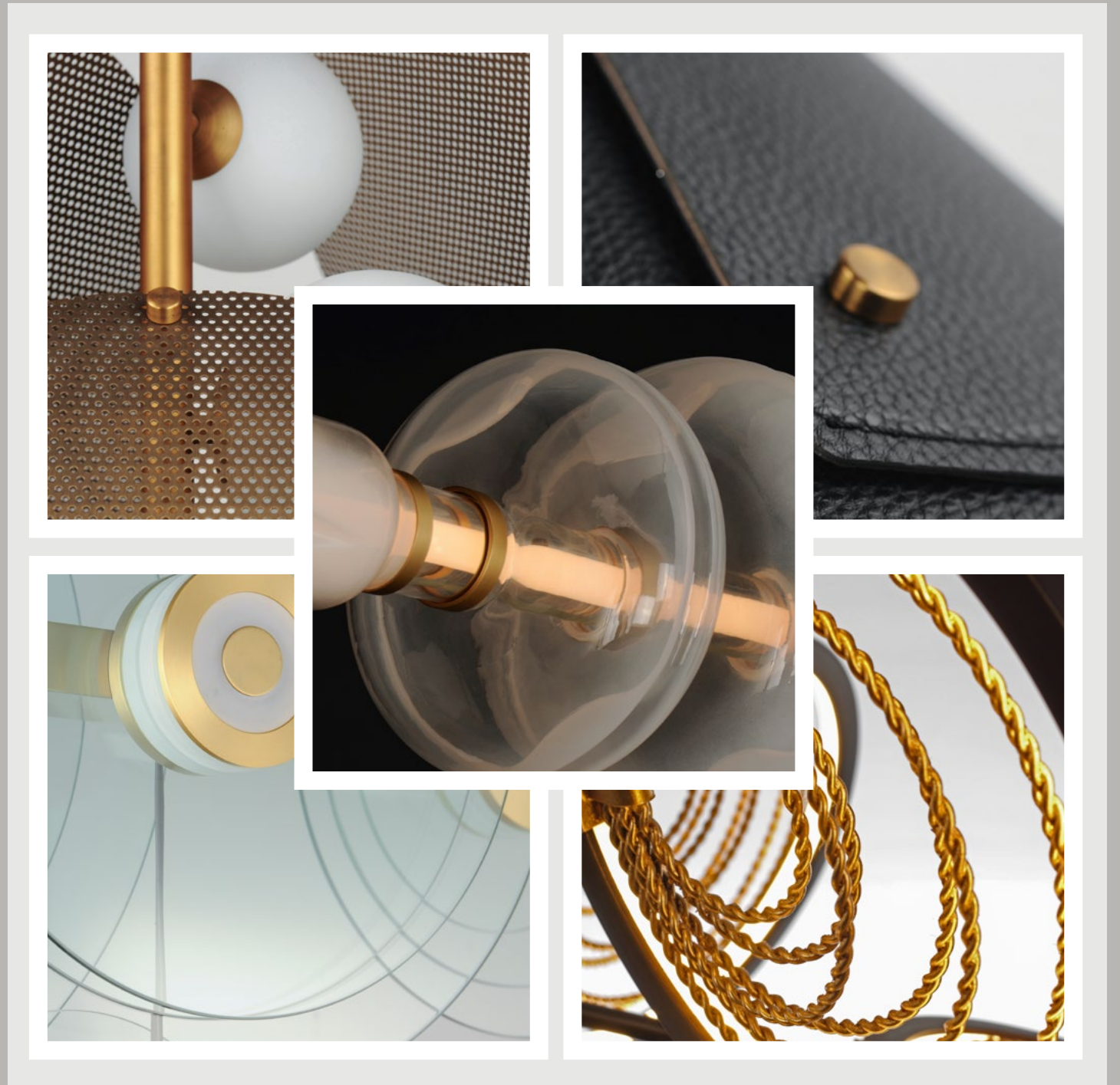

STUDIO•M

SIGNATURES



REFRESHINGLY MODERN, RETRO COOL

# STUDIO•M

REFRESHINGLY MODERN, RETRO COOL



CÉSAR GIRALDO  
Pg. 32

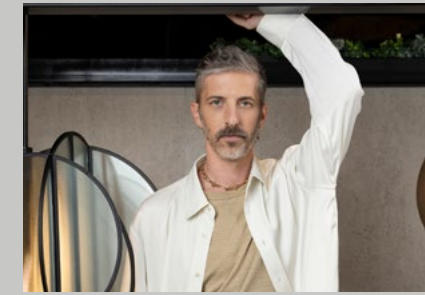

MAT SANDERS  
Pg. 106



NINA MAGON  
Pg. 38

|            |         |
|------------|---------|
| ALINA      | Pg. 68  |
| ARYA       | Pg. 86  |
| CAVALIER   | Pg. 138 |
| CHAPEAU    | Pg. 108 |
| CHIPS      | Pg. 112 |
| CONTOUR    | Pg. 48  |
| CRADLE     | Pg. 156 |
| CRESCENDO  | Pg. 24  |
| CRUX       | Pg. 130 |
| DOLCE VITA | Pg. 76  |
| DOMAIN     | Pg. 118 |
| DREAMER    | Pg. 63  |
| EMPIRE     | Pg. 16  |
| GUSTO      | Pg. 32  |
| HOURGLASS  | Pg. 104 |
| INCOGNITO  | Pg. 126 |
| JEFFERSON  | Pg. 40  |
| LARIAT     | Pg. 30  |
| LILLET     | Pg. 10  |
| LOCKET     | Pg. 44  |
| MANHATTAN  | Pg. 20  |
| MEDALLION  | Pg. 80  |

|             |         |
|-------------|---------|
| MEGALITH    | Pg. 90  |
| NEW AGE     | Pg. 102 |
| NORMA JEANE | Pg. 160 |
| PEONY       | Pg. 06  |
| PRISMATIC   | Pg. 144 |
| ROLLAND     | Pg. 14  |
| SATELLITE   | Pg. 105 |
| SCAN        | Pg. 26  |
| STITCHED    | Pg. 56  |
| STONEWALL   | Pg. 98  |
| STRATUM     | Pg. 82  |
| TRANCE      | Pg. 40  |
| TRAPEZE     | Pg. 154 |
| UNITY XL    | Pg. 158 |
| VESTA       | Pg. 134 |
| ZEPPELIN    | Pg. 72  |
| 10 CARAT    | Pg. 150 |



DAMP



WET



ADA ADA



CCT SELECT

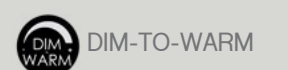

DIM-TO-WARM

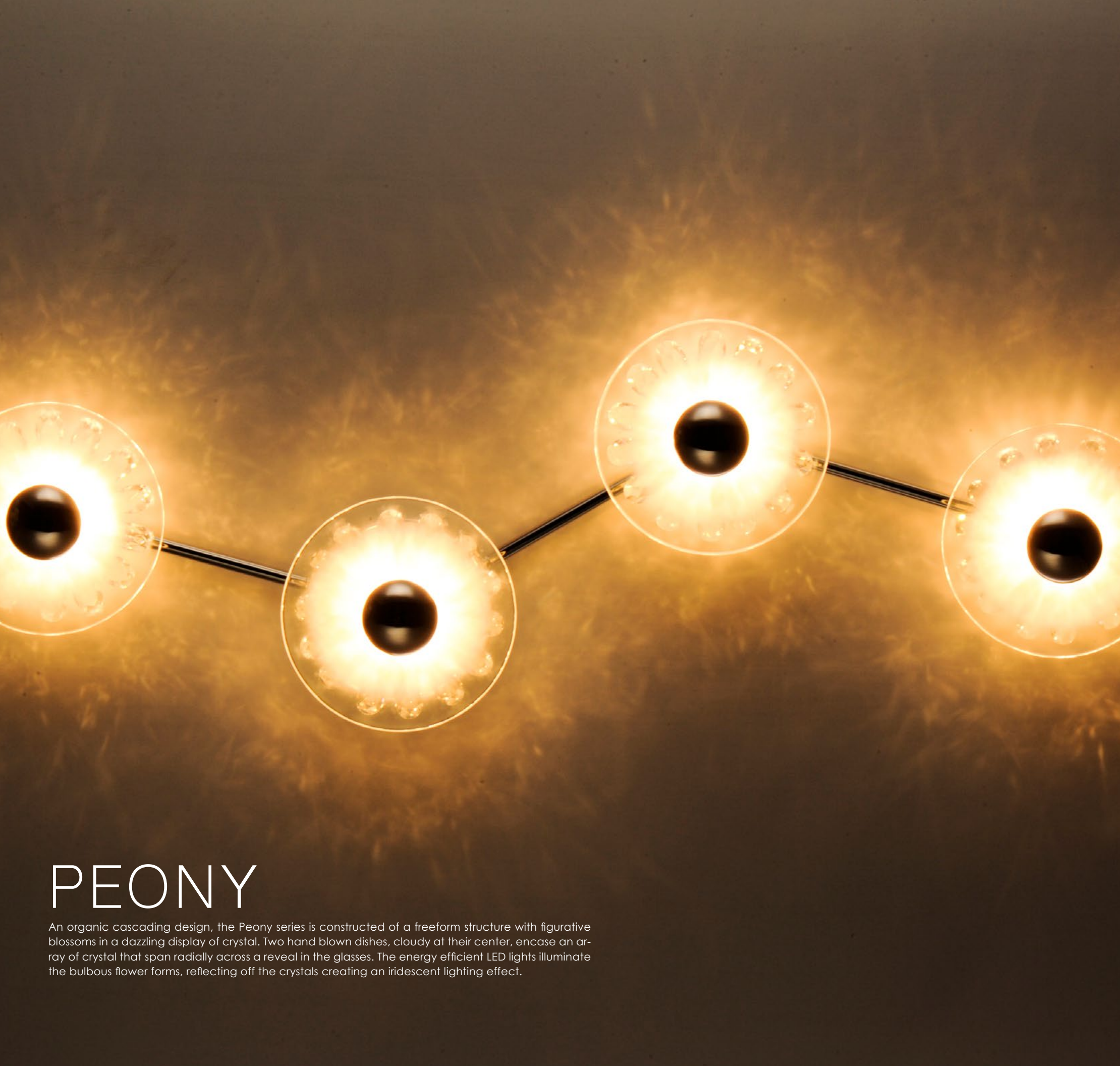

# PEONY

An organic cascading design, the Peony series is constructed of a freeform structure with figurative blossoms in a dazzling display of crystal. Two hand blown dishes, cloudy at their center, encase an array of crystal that span radially across a reveal in the glasses. The energy efficient LED lights illuminate the bulbous flower forms, reflecting off the crystals creating an iridescent lighting effect.

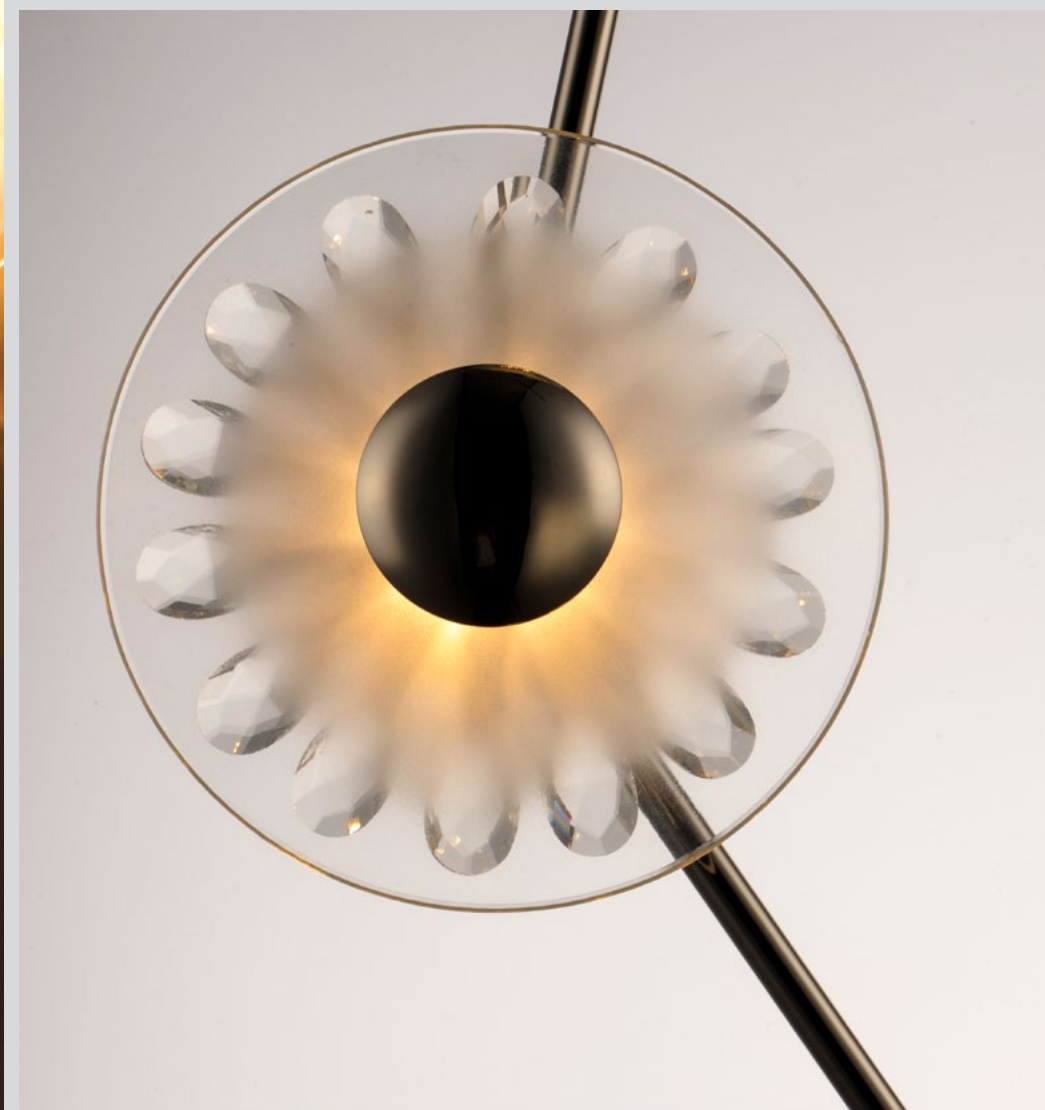



SM23873



SM23875



SM23874



SM23877

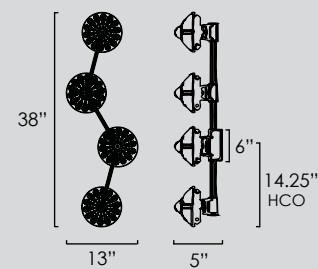

SM23873 • Sconce

(4) 4.5W LED PCB (integrated)  
 9"L x 13"H x 5"E  
 BP: 6"W x 6"H, 14.25" HCO  
 3000K, CRI 90+, 1250 lm

Available in Polished Nickel with Clear glass (FTCLPN)

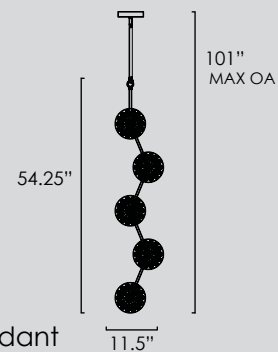

SM23875 • Vertical Pendant

(10) 4.5W LED PCB (integrated)  
 6"W x 54.25"H, 101"Max OA  
 Canopy: 6"W x 1.25"H x 6"L  
 3000K, CRI 90+, 3000 lm

Available in Polished Nickel with Clear glass (FTCLPN)

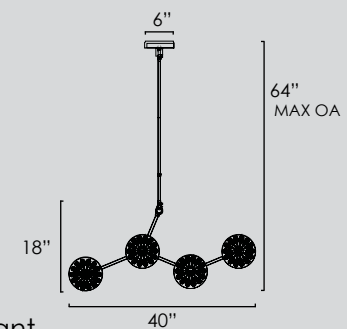

SM23874 • Pendant

(8) 4.5W LED PCB (integrated)  
 6"W x 18"H x 40"L, 64" Max OA  
 Canopy: 6"W x 1.25"H x 6"L  
 3000K, CRI 90+, 2500 lm

Available in Polished Nickel with Clear glass (FTCLPN)

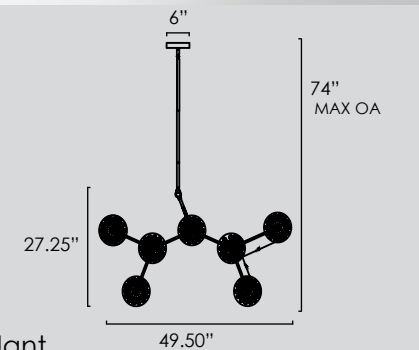

SM23877 • Linear Pendant

(14) 4.5W LED PCB (integrated)  
 6"W x 27.25"H x 49.5"L, 74" Max OA  
 Canopy: 6"W x 1.25"H x 6"L  
 3000K, CRI 90+, 4200 lm

Available in Polished Nickel with Clear glass (FTCLPN)



# LILLET

Stunning LED arrangements recreate the splendor of Art Nouveau. The biophilic forms that sparkle in this distinctive structure are made of feather-like handcrafted steel and crystal. These crystal sculptures are evenly lit by a discrete strip of LED light that follows the sculpture's undulating shape, which also adds additional ambient light below. Available in various pendant configurations and a coordinating sconce and finished in Polished Nickel.



SM23819

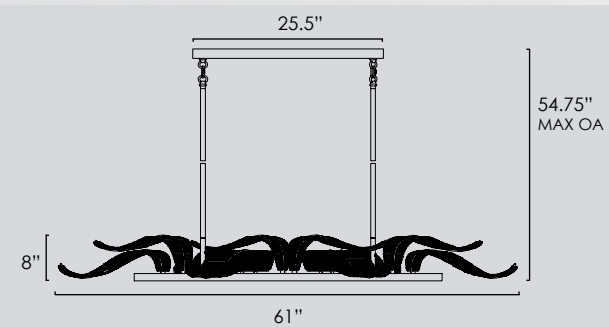

SM23819 • Linear Pendant

50W LED DC (integrated)  
 26.25"W x 8"H x 61" L, 54.75" Max OA  
 Canopy: 5"W x 1.5"H x 25.5"L  
 3000K, CRI 90+, 3000 lm

Available in Beveled Crystal in Polished Nickel (BCPN) or Gold (BCGLD)





SM23810

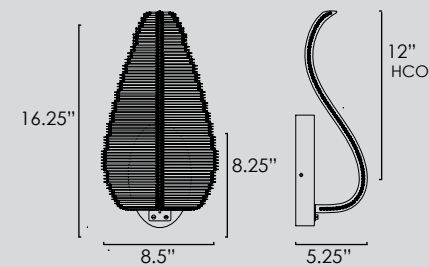

SM23810 • Sconce

5W LED DC (integrated)  
 8.5"W x 16.25"H x 5.25"E, 12" HCO  
 BP: 5"W x 8.25"H x 1.5"L  
 3000K, CRI 90+, 300 lm

Available in Beveled Crystal in Polished Nickel (BCPN)  
 or Gold (BCGLD)



SM23813

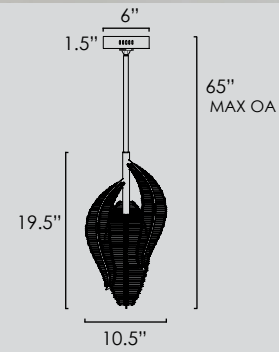

SM23813 • Single Pendant

12W LED DC (integrated)  
 10.5"W x 19.5"H x 10.5"L, 65" Max OA  
 Canopy: 6"W x 1.5"H x 6"L  
 3000K, CRI 90+, 720 lm

Available in Beveled Crystal in Polished Nickel (BCPN)  
 or Gold (BCGLD)



SM23816

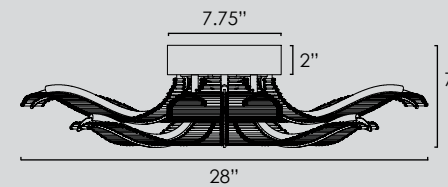

SM23816 • Flush Mount

18W LED DC (integrated)  
 28"W x 7"H x 28" L  
 Canopy: 7.75"W x 2"H x 7.75"L  
 3000K, CRI 90+, 1260 lm

Available in Beveled Crystal in Polished Nickel (BCPN)  
 or Gold (BCGLD)





# ROLLAND

Like the subtle sweep of a painter's brush, the Rolland pulsates with durable elegance mimicking the rhythmic swell of a wave. Custom K9 Crystal's suspend brilliantly from the undulating stainless steel LED ring that is upheld by a breathtaking crystal infused canopy. The attentiveness to detail combined with dimmable features cultivate elegance that can only be accomplished by dynamism of shape.



SM23838

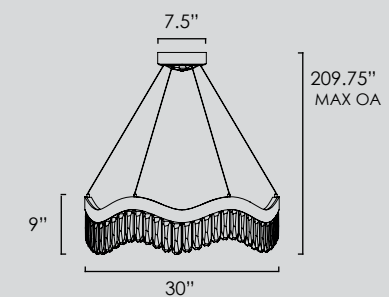

SM23838 • Chandelier

55W LED PCB (integrated)  
 30"W x 9"H x 30"L, 209.75" Max OA  
 Canopy: 7.5"W x 1.75"H, 7.5"L,  
 3000K, CRI 80+, 2964 lm

Available in Polished Nickel with Beveled Crystal (BCPN)

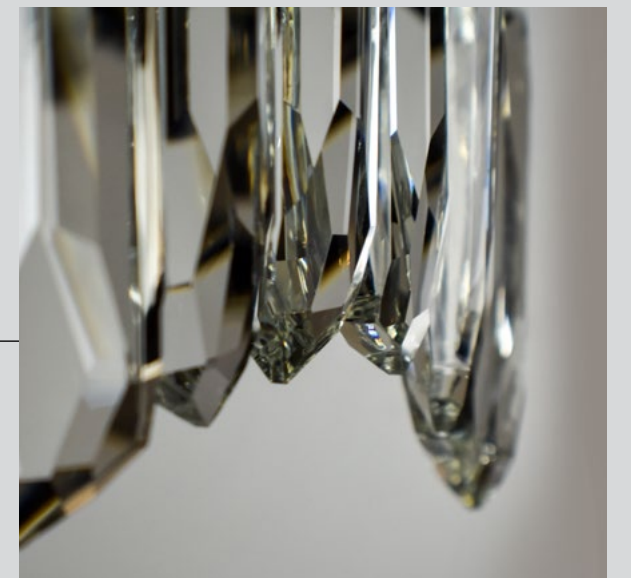





# EMPIRE

Architecturally inspired by cityscapes, the faceted-cut crystal forms replace conventional chandelier glass on the ring bar framework finished in French Gold. Additional down lighting is diffused through jewel-like crystals.



SM23645

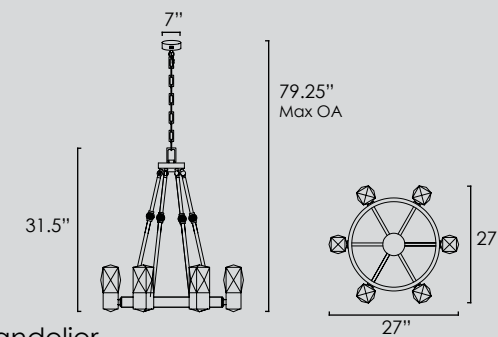

SM23645 • Chandelier

(12) 4.5W LED PCB (integrated)  
 27"W x 31.5"H x 27"L, 79.25" Max OA  
 Canopy: 7"W x 2"H  
 3000K, CRI 80+, 3780 lm

Available in Polished Nickel (BCPN)





SM23640

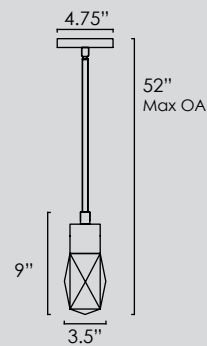

SM23640 • Single Pendant

8W LED PCB (integrated)  
 3.5"W x 9"H x 3.5"L, 52" Max OA  
 Canopy: 4.75"W x 1"H  
 3000K, CRI 90+, 720 lm

Available in French Gold (BCFG) Polished Nickel (BCPN)



SM23641

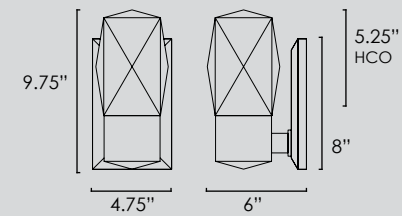

SM23641 • Sconce

(2) 4.5W LED PCB (integrated)  
 4.75"W x 9.75"H x 6"E  
 BP: 4.75"W x 8"H, 5.25" HCO  
 3000K, CRI 90+, 630 lm

Available in French Gold (BCFG) Polished Nickel (BCPN)



SM23642

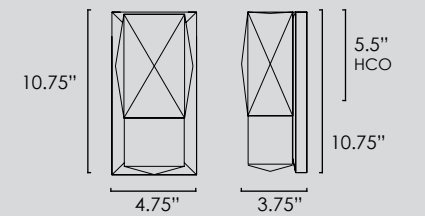

SM23642 • ADA Sconce

(2) 4W LED PCB (integrated)  
 4.75"W x 10.75"H x 3.75"E  
 BP: 4.75"W x 10.75"H, 5.5" HCO  
 3000K, CRI 90+, 650 lm

Available in French Gold (BCFG) Polished Nickel (BCPN)





# MANHATTAN

The timeless chandelier form is transformed in an elegantly stripped down update. Black drum shades lined with Studio • M's iconic Metallic Silver Pattern are paired with simple cut glass bobeches, conveying refined elegance and modern simplicity.





SM23754

SM23755

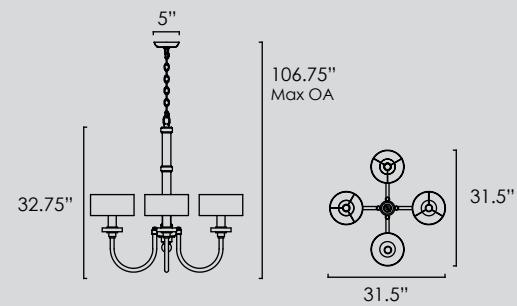

SM23754 • Chandelier

(4) 60W E26 Incandescent  
31.5"W x 32.75"H x 31.5"L, 106.75" Max OA  
Canopy: 5"W x 1"H

Available in Polished Silver with Black Tie Shade (BTPS)

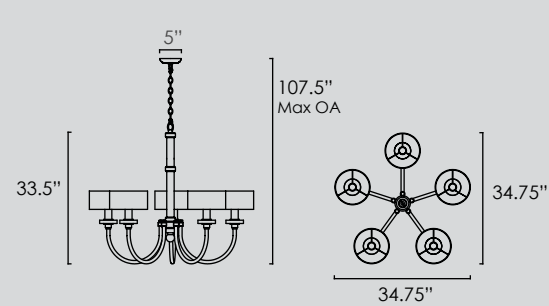

SM23755 • Chandelier

(5) 60W E26 Incandescent  
34.75"W x 33.5"H x 34.75"L, 107.5" Max OA  
Canopy: 5"W x 1"H

Available in Polished Silver with Black Tie Shade (BTPS)



SM23751

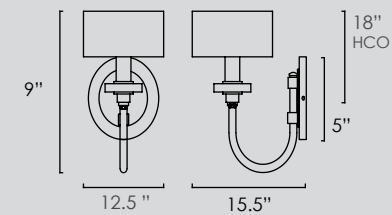

SM23751 • Sconce

(1) 60W E26 Incandescent  
12.5"W x 9"H x 15.50"E  
BP: 5"W x 5"H, 8.25" HCO

Available in Polished Silver with Black Tie Shade (BTPS)





SM23805



SM23800

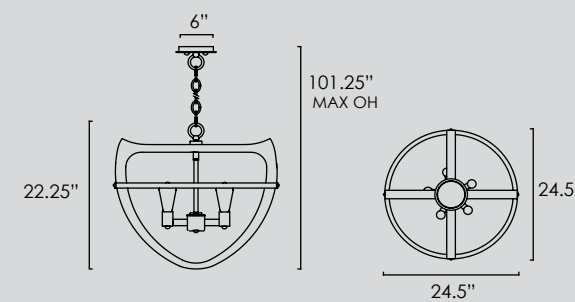

SM23805 • Chandelier

(5) 60W Incandescent E26  
 24.5"W x 22.25"H x 24.5"L, 101.25" Max OA  
 Canopy: 6"W x 1"H

Available in Wenge with Polished Nickel (WEPN)

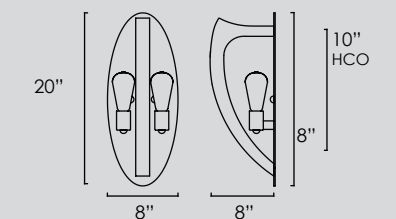

SM23800 • Sconce

(2) 60W Incandescent E26  
 8"W x 20"H x 8"E  
 BP: 8"W x 1"H, 10" HCO

Available in Wenge with Polished Nickel (WEPN)

# CRESCENDO

Cube framed fixtures of brass, steel, and wood have been transformed with the remarkable form of the Crescendo series. Pairing this innovative design with luxurious finishing, the solid wood cage is done in a dark Wenge, popularized in furniture, metalwork is done in a complimentary Polished Nickel finish. Complete this look with decorative filament lamps, either LED filament or vintage carbon Edison lamps.



# SCAN

A modern expression using natural materials, Scan features a stained Walnut wood wire way. Clear conical glass is suspended by Black Rayon cord and completed with Polished Nickel metalwork. 40 Watt Xenon G9 bulbs included



SM23825

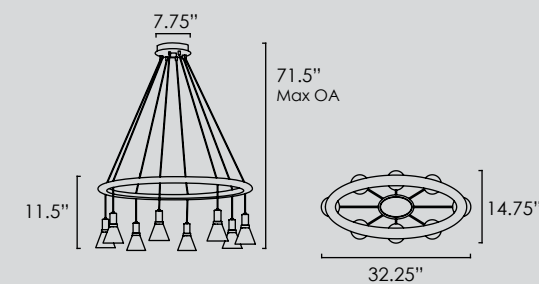

SM23825 • Chandelier

(8) 40W G9 Xenon (included)  
14.75"W x 11.5"H x 32.25"L, 71.5" Max OA  
Canopy: 5"W x 1.5"H x 7.5"L

Available in Clear glass with Walnut (CLWN)



SM23827

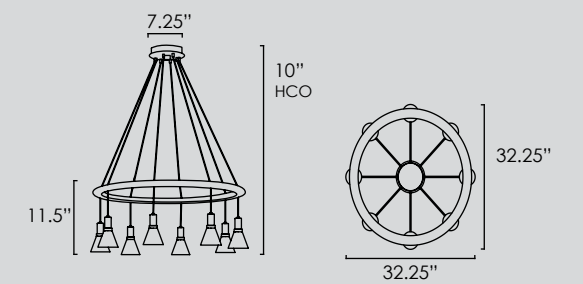

SM23827 • Chandelier

(8) 40W G9 Xenon (included)  
32.25"W x 11.5"H x 32.25"L, 71.5" Max OA  
Canopy: 7.25"W x 1.5"H x 7.25"L

Available in Clear glass with Walnut (CLWN)



SM23820

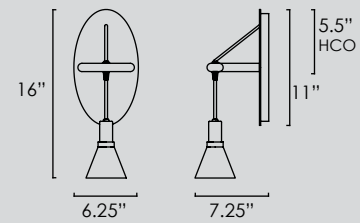

SM23820 • Sconce

(1) 40W G9 Xenon (included)  
6.25"W x 16"H x 7.25"E  
BP: 6.25"W x 11"H, 5.5" HCO

Available in Clear glass with Walnut (CLWN)

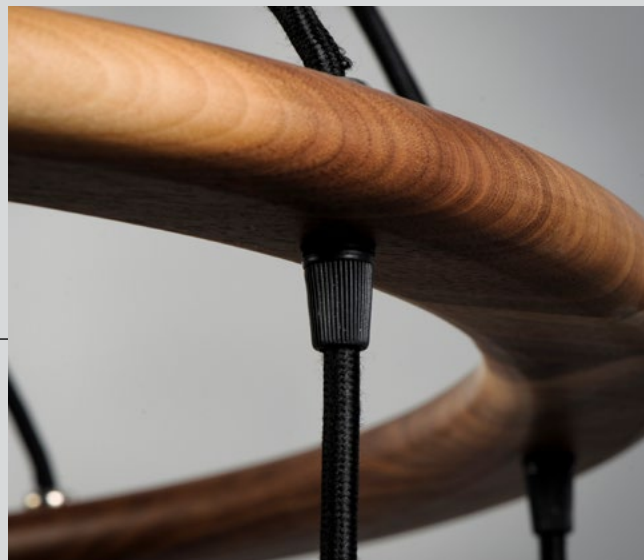



# LARIAT

An entirely modern interpretation on the classic multi-tiered chandelier, Lariat features dramatically radiating arms in opposing directions. Using energy efficient LED technology, this artfully sculpted chandelier exemplifies intelligent luxury. Rings of LED illuminate frame hand crafted metalwork that is elegantly braided and gold leafed. The contrast of the Gold Leaf with a dark Bronze Guilt finish further enhances this contemporary piece. Thoughtful in design, the Lariat's swiveling canopy, adjustable arms and rotating heads, offers personal configuration with simple adjustments.



SM23845

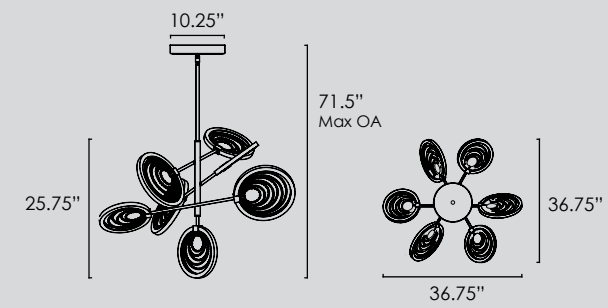

SM23845 • Pendant

123W LED PCB (integrated)  
36.75"W x 25.75"H x 36.75"L, 71.5" Max OA  
Canopy: 10.25"D x 1.5"H  
3000K, CRI 80+, 1400 lm

Available in Bronze Guilt with Gold Leaf (BZGTGL)

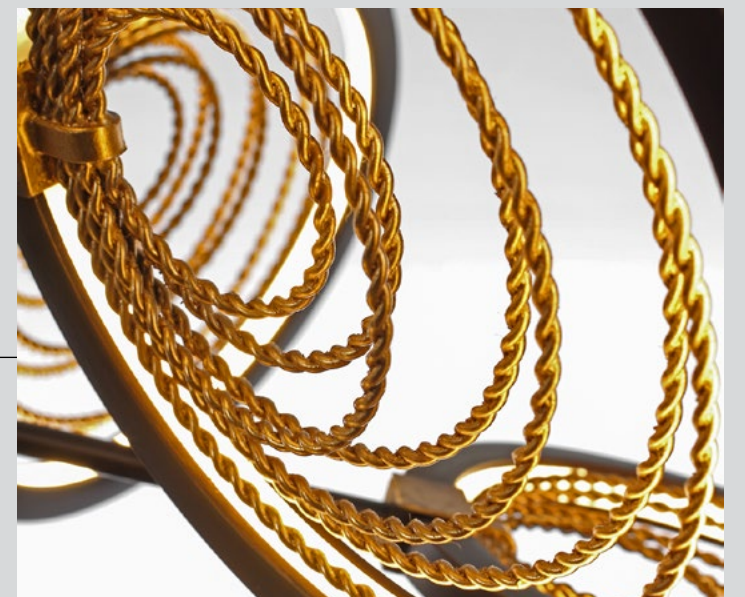





# CÉSAR GIRALDO

## GUSTO CAPSULE COLLECTION



Futuristic and full of Gusto, the capsule collection designed by Cesar Giraldo features artisanal hand-blown glass elements colored in cloud-like white infused glass or gradients of smoked grey and warm amber tones. The glasses' hand-crafted dimples refract dedicated LED lighting that highlights an undulating silhouette throughout the fixture. Diffused evenly across a thin tube of white acrylic encased within a larger vacuum of clear glass, the airy compositions appear to be floating while amply filling spaces.

Configurations include both horizontal and linear pendants, ceiling mounts, wall sconces and portable lamps sized for multiple applications. Available in metal accents finished in Gunmetal or Gold.



SM18597

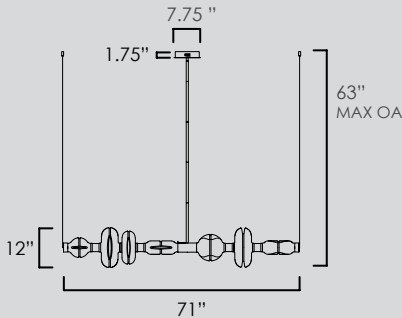

SM18597 • Linear Pendant

38.5W LED DC (Integrated)  
12"D x 12"H, 71"L, 63"Max OA  
Canopy: 7.75"W x 7.75"L 1.75"H  
3000K, CRI 90+, 2700 lm

Available in Gold (GLD) Gunmetal (GM)

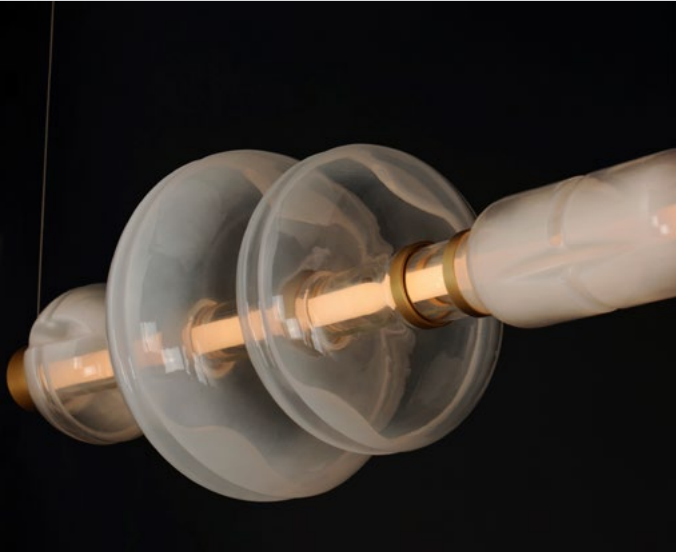



SM18592 • Pendant

11.5W LED DC (Integrated)  
 12"D x 21.5"H, 12"L, 144"Max OA  
 Canopy: 6.25"W x 6.25"L 1.5"H  
 3000K, CRI 90+, 810 lm

Available in Gold (GLD) Gunmetal (GM)

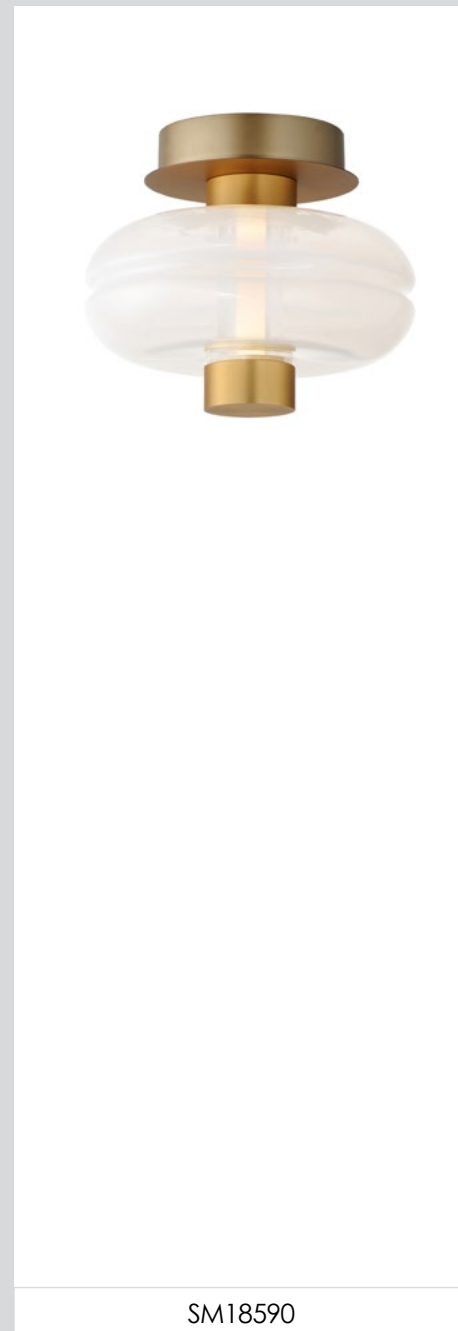

SM18590

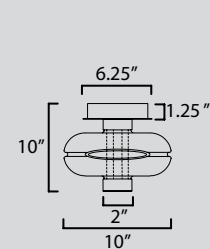

SM18590 • Sconce / Flush Mount

5W LED DC (Integrated)  
 10"W x 10"H, 8"E  
 Canopy: 6.25"W x 6.25"L 1.25"H  
 3000K, CRI 90+, 220 lm

Available in Gold (FGGLD) Gunmetal (FMGM)

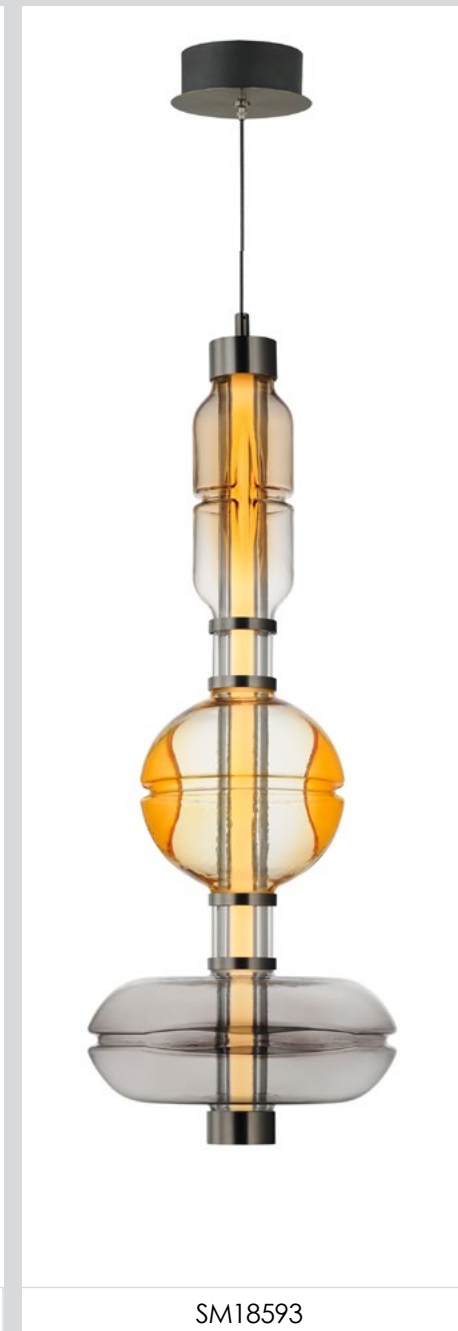

SM18593

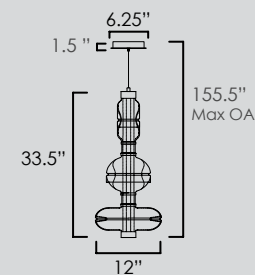

SM18593 • Pendant

18W LED DC (Integrated)  
 12"D x 33.5"H, 155.5"Max OA  
 Canopy: 6.25"W x 6.25"L 1.5"H  
 3000K, CRI 90+, 1260 lm

Available in Gold (GLD) Gunmetal (GM)



SM18594

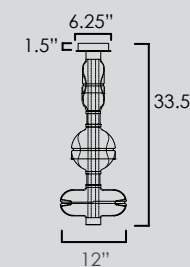

SM18594 • Ceiling Mount

18W LED DC (Integrated)  
 12"D x 33.5"H  
 Canopy: 6.25"W x 6.25"L 1.5"H  
 3000K, CRI 90+, 1260 lm

Available in Gold (GLD) Gunmetal (GM)



SM18598

SM18595

SM18599

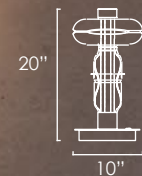

SM18595 • 20" Table Lamp

9.5W LED DC (Integrated)  
10"D x 20"H  
Wire Length: 72"  
3000K, CRI 90+, 670 lm

Available in Gold (GLD) Gunmetal (GM)



SM18598 • Table Lamp

14.5W LED DC (Integrated)  
10"D x 28"H  
Wire Length: 72"  
3000K, CRI 90+, 1300 lm

Available in Gold (GLD) Gunmetal (GM)

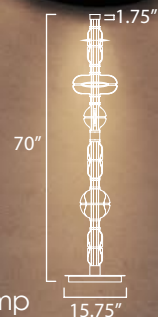

SM18599 • Floor Lamp

38.5W LED DC (Integrated)  
12"D x 70"H  
Wire Length: 72"  
3000K, CRI 90+, 2700 lm

Available in Gold (GLD) Gunmetal (GM)



SM18591

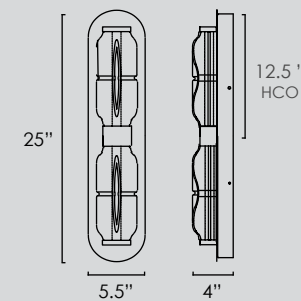

SM18591 • Sconce

14W LED DC (Integrated)  
5.5"W x 25"H x 4"E  
BP: 5.5"W x 25"H, 12.5" HCO  
3000K, CRI 90+, 300 lm

Available in Frosted Glass with Gold and Gunmetal (FGGLDGM)





# NINA | MAGON™

Globally renowned for creating spectacular spaces, Nina Magon, founder and principal of Contour Interior Design, is a multifaceted interior designer, delivering luxurious residential, commercial, and hospitality projects, inclusive of a curated collection of lifestyle product designs. Known for her edgy and bold aesthetic, she infuses each design with her signature style by using bold elements, color, and timeless modernity. Nina creates uniquely luxurious spaces and pieces, which excite the senses and are inspired by worldly cultures, to deliver excellence to her discerning clientele. In addition to her numerous design awards and recognition, Nina has been featured in distinguished publications including Architectural Digest, Elle Décor, Interior Design Magazine, Hospitality Design Magazine, Luxe Magazine, The Robb Report, Wall Street Journal and many more.



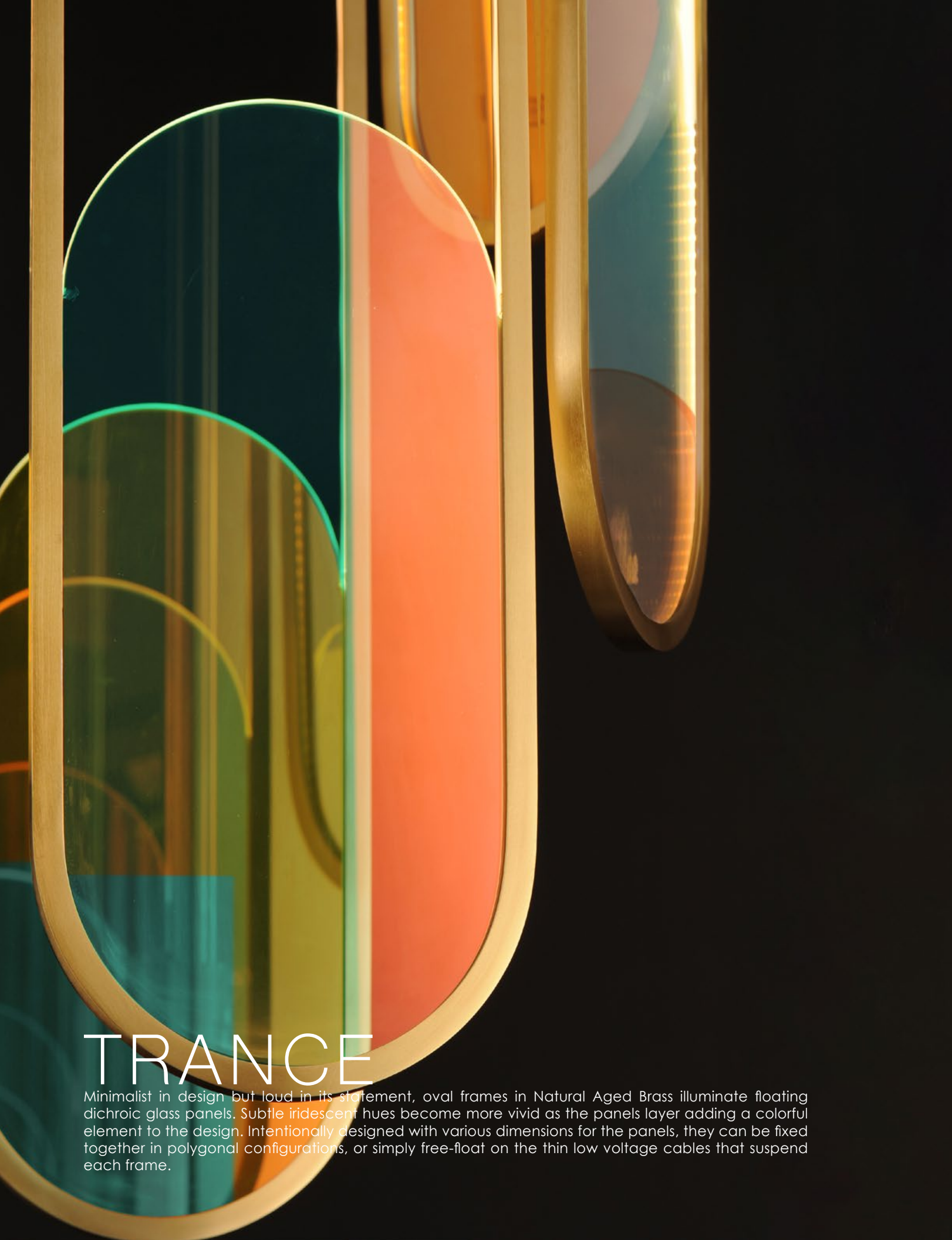

# TRANCE

Minimalist in design but loud in its statement, oval frames in Natural Aged Brass illuminate floating dichroic glass panels. Subtle iridescent hues become more vivid as the panels layer adding a colorful element to the design. Intentionally designed with various dimensions for the panels, they can be fixed together in polygonal configurations, or simply free-float on the thin low voltage cables that suspend each frame.

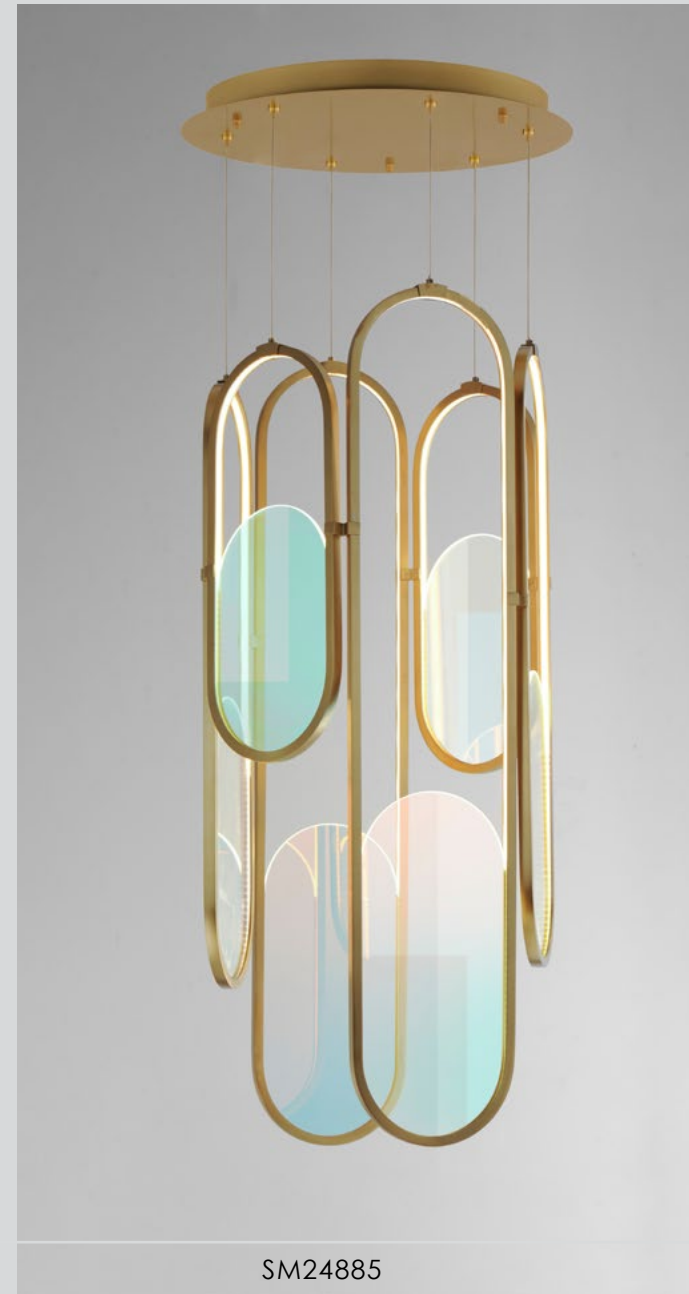

SM24885

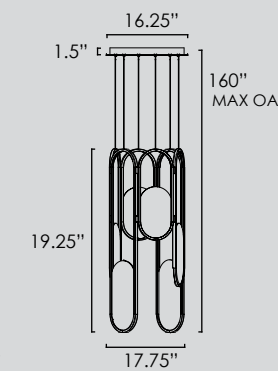

SM24885 • Pendant

102W LED DC (integrated)  
17.75"D x 39.25"H, 160" Max OA  
Canopy: 16.25"D x 1.5"H  
3000K, CRI 90+, 4800 lm

Available in Dichroic Panel  
w/ Natural Aged Brass(DCNAB)



SM24883

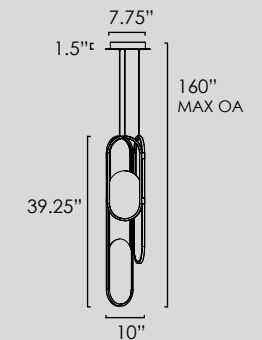

SM24883 • Pendant

14W LED DC (integrated)  
10"D x 39.25"H, 160" Max OA  
Canopy: 7.75"D x 1.5"H  
3000K, CRI 90+, 2640 lm

Available in Dichroic Panel  
w/ Natural Aged Brass(DCNAB)



SM24881



SM24882



SM24889

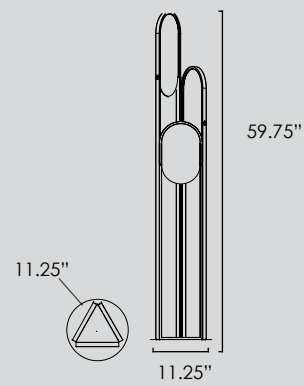
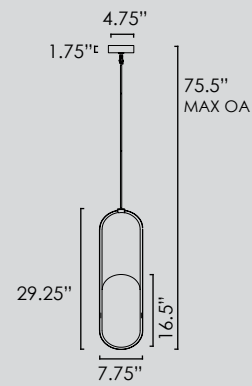
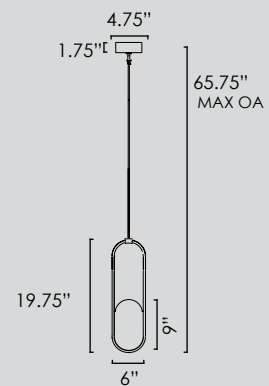

SM24881 • Mini Pendant

SM24882 • Single Pendant

SM24889 • Floor Lamp

14W LED DC (integrated)  
0.75"W x 19.75"H x 6"L, 65.75" Max OA  
Canopy: 4.75"D x 1.75"H  
3000K, CRI 90+, 580 lm

26W LED DC (integrated)  
0.75"W x 29.25"H x 7.75"L, 75.5" Max OA  
Canopy: 4.75"D x 1.75"H  
3000K, CRI 90+, 1270 lm

69W LED DC (integrated)  
11.25"W x 59.75"H x 11.25"L,  
Wire: 72"  
3000K, CRI 90+, 3360 lm

Available in Dichroic Panel  
w/ Natural Aged Brass(DCNAB)

Available in Dichroic Panel  
w/ Natural Aged Brass(DCNAB)

Available in Dichroic Panel  
w/ Natural Aged Brass(DCNAB)

# LOCKET

The alluring visual effect of a milky cloud marble glass provides elegant luminosity. Backlit with evenly diffused LED lighting the fixtures resonate like a vibrant musical note. The fixture is elongated with a vertical metal spike finished in Natural Aged Brass that hugs the glass' shape as it extends in both directions. These elements end in an angle-cut edge which adds visual contrast not only in color but in feeling. The sharpness of a clasp to the softer orb of the marbling white glass. An embodiment of lighting as a jewel, the Locket evokes both the opulence and sentimentality of designer accessories.

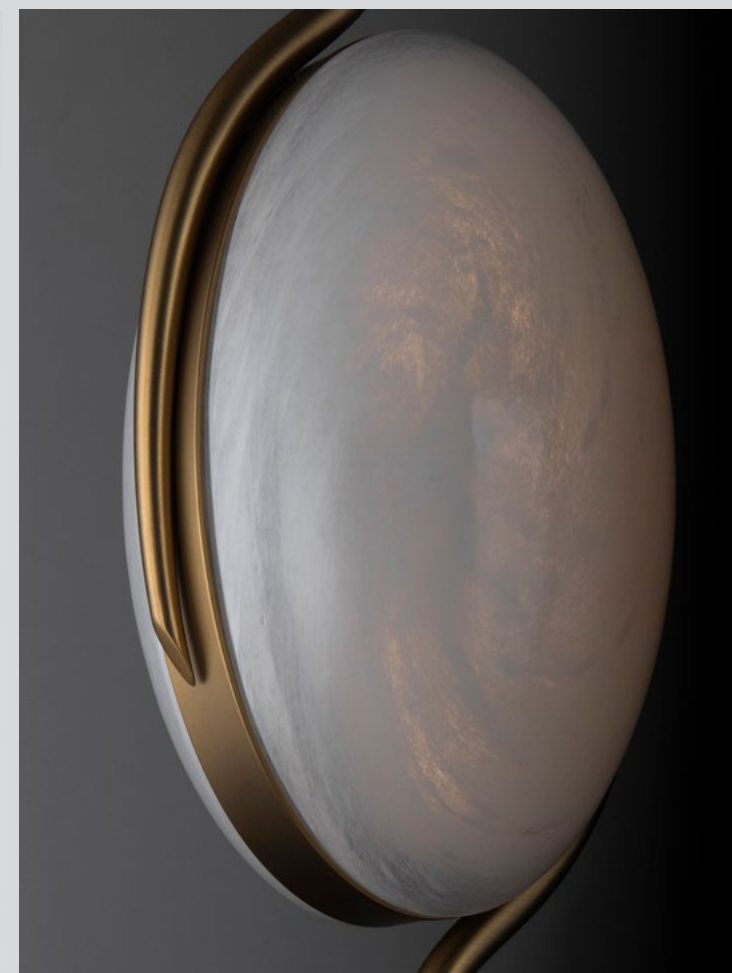



SM24873



SM24871



SM24870

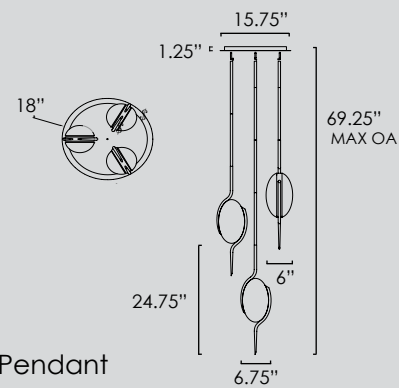

SM24873 • Multi - Pendant

48W LED PCB (integrated)  
18"D x 24.75"H, 69.25" Max OA  
Canopy: 15.75"D x 1.25"H  
3000K, CRI 90+, 3070 lm

Available in Marble Glass w/Natural Aged Brass (MRNAB)

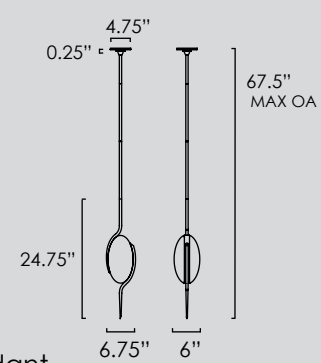

SM24871 • Single Pendant

16W LED PCB (integrated)  
6"W x 24.75"H x 6.75"L, 67.5" Max OA  
Canopy: 4.75"D x 0.25"H  
3000K, CRI 90+, 1280 lm

Available in Marble Glass w/Natural Aged Brass (MRNAB)

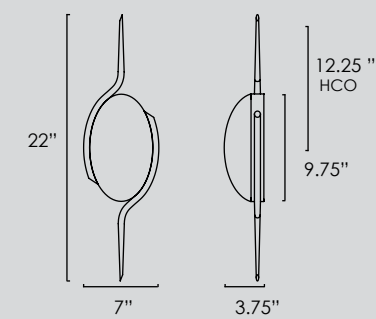

SM24870 • Sconce

8W LED PCB (integrated)  
7"W x 24.5"H x 3.75"E  
BP: 6"W x 9.75"H, 12.25" HCO  
3000K, CRI 90+, 640 lm

Available in Marble Glass w/Natural Aged Brass (MRNAB)







# CONTOUR

Gentle curves descend from the ceiling and pop with spheres of satin white glass shades. Strikingly modern, yet elegantly timeless the Contour series exemplifies Nina Magon's design aesthetic using curved silhouettes and bold applications of color. Offered in a variety of rich metallic finishes including Brushed Bronze, Heritage Brass, and Polished Chrome as well as made-to-order powder coat finishes, this collection provides the flexibility to match more spaces. Choose either warm 3000k or bright white 4000k LED lamps included and complete this energy-efficient solution that'll add visual interest to your space that can last generations.





SM24903



SM24905



SM24906

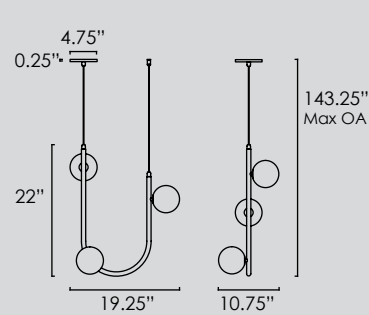

SM24903 • Cord Hung Pendant

(3) 4W LED G9 (included)  
 10.75"W x 22"H x 19.25"L, 143.25" Max OA  
 Canopy: 4.75"W x 0.25"H  
 BBZ version is 3000K 1050 lm, CRI 90+  
 HR version is 3000K 1040 lm, CRI 90+  
 PC version is 4000K 1040 lm, CRI 90+

Available in Brushed Bronze (BBZ)  
 Heritage Brass (HR) Polished Chrome (PC)

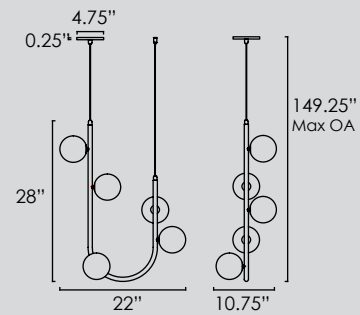

SM24905 • Cord Hung Pendant

(5) 4W LED G9 (included)  
 10.75"W x 28"H x 22"L, 149.25" Max OA  
 Canopy: 4.75"W x 0.25"H  
 BBZ version is 3000K 1740 lm, CRI 90+  
 HR version is 3000K 1740 lm, CRI 90+  
 PC version is 4000K 1740 lm, CRI 90+

Available in Brushed Bronze (BBZ)  
 Heritage Brass (HR) Polished Chrome (PC)

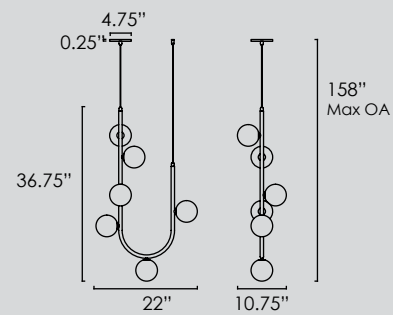

SM24906 • Cord Hung Pendant

(6) 4W LED G9 (included)  
 10.75"W x 36.75"H x 22"L, 158" Max OA  
 Canopy: 4.75"W x 0.25"H  
 BBZ version is 3000K 2090 lm, CRI 90+  
 HR version is 3000K 2090 lm, CRI 90+  
 PC version is 4000K 2090 lm, CRI 90+

Available in Brushed Bronze (BBZ)  
 Heritage Brass (HR) Polished Chrome (PC)





SM24914



SM24919



SM24916

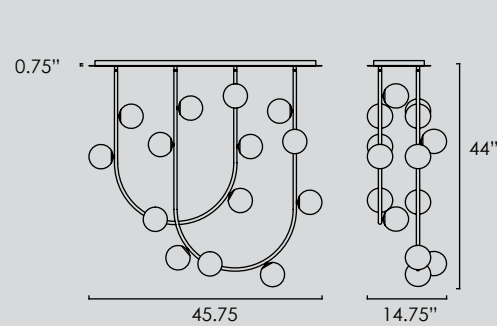

SM24914 • Fixed Stem Chandelier

(14) 4W LED G9 (included)  
 14.75"W x 44"H x 45.75"L  
 Canopy: 11.75"W x 0.75"H x 45.75"L  
 BBZ version is 3000K 4870 lm, CRI 90+  
 HR version is 3000K 4870 lm, CRI 90+  
 PC version is 4000K 4870 lm, CRI 90+

Available in Brushed Bronze (BBZ)  
 Heritage Brass (HR) Polished Chrome (PC)

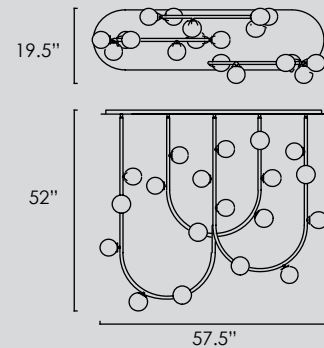

SM24919 • Fixed Stem Chandelier

(19) 4W LED G9 (included)  
 19.5"W x 52"H x 57.5"L  
 Canopy: 15.75"W x 0.75"H x 57"L  
 BBZ version is 3000K 6610 lm, CRI 90+  
 HR version is 3000K 6610 lm, CRI 90+  
 PC version is 4000K 6610 lm, CRI 90+

Available in Brushed Bronze (BBZ)  
 Heritage Brass (HR) Polished Chrome (PC)

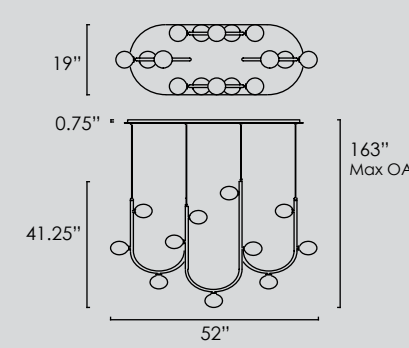

SM24916 • Cord Hung Chandelier

(16) 4W LED G9 (included)  
 19"W x 41.25"H x 52"L, 163" Max OA  
 Canopy: 19"W x 0.75"H x 45"L  
 BBZ version is 3000K 5570 lm, CRI 90+  
 HR version is 3000K 5570 lm, CRI 90+  
 PC version is 4000K 5570 lm, CRI 90+

Available in Brushed Bronze (BBZ)  
 Heritage Brass (HR) Polished Chrome (PC)

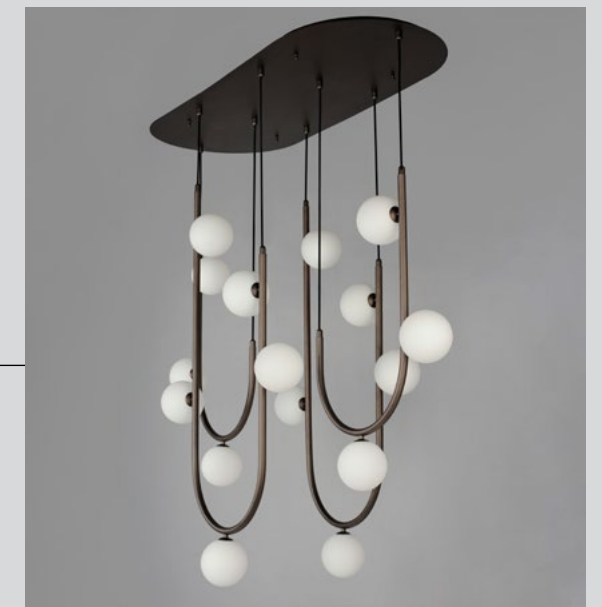

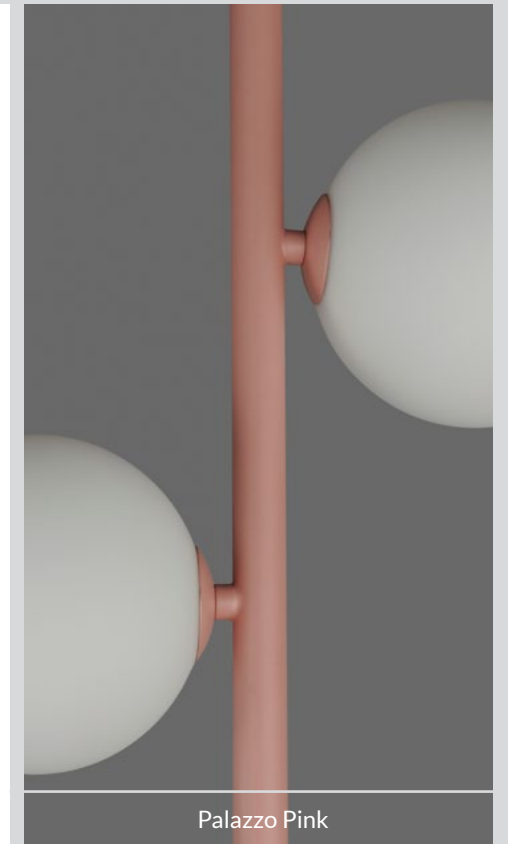

Palazzo Pink

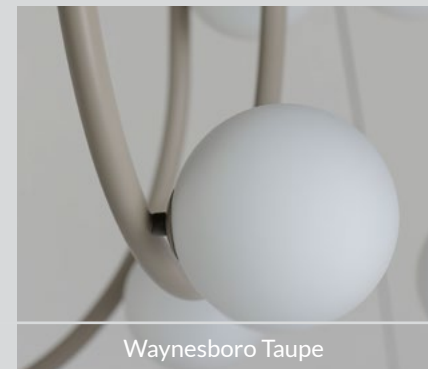

Waynesboro Taupe

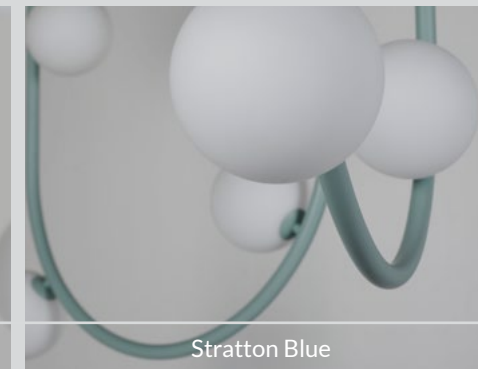

Stratton Blue



Oxford White

**CONTOUR**  
MADE TO ORDER  
FIXTURES

Make Nina Magon's Contour pendants your own! This configuration will allow you to customize the size, LED lamp color, and best of all Made-to-Order powder coat finishes. Choose from our recommended library of curated finishes selected by Nina such as Oxford White, Stratton Blue, Taupe, or Palazzo Pink as seen in the highly-regarded work of Nina Magon at the Kips Bay Design House in West Palm Beach. If a custom configuration or finish is not shown, please reach out to our specialized Concierge team and we'll contact you within 24 hours! With Made-to-Order options, get greater design flexibility on an already beloved collection.

**Canopy Options**

- Single Port fixed (SM249XX)
- 3 Port Round (SMC1003WT)
- 5 Port Round (SMC1005WT)
- 6 Port Round (SMC1006WT)

**Arm Options**

- 5 Light (SMP24905) (5) 4W LED G9
- 6 Light (SMP24906) (6) 4W LED G9

**Available Powder Coats**

- Palazzo Pink (PP)
- Waynesboro Taupe (TP)
- Stratton Blue (SB)
- Oxford White (WT)

**Color Temperature**

3000K or 4000K

**BUILD YOUR OWN CONTOUR USING OUR ONLINE CONFIGURATER**



# STITCHED

Expertly fabricated metalwork constructed to support artisan craft leather-work in Dark Brown tones. Configured to illuminate orbs of light supported at various positions, the white glass spheres cast ambient light from the included LED lamps diffused within. The hand applied Brushed Bronze finish compliments the luxurious, genuine Dark Brown leather creating a warm soft modern lighting product. Conspicuously joined together around the frame's center, the leather features eye-catching saddle stitching. An exercise in master craftsmanship, the Stitched Collection presents a playful, yet handsomely casual lighting collection that agrees with both modern and transitional aesthetics.

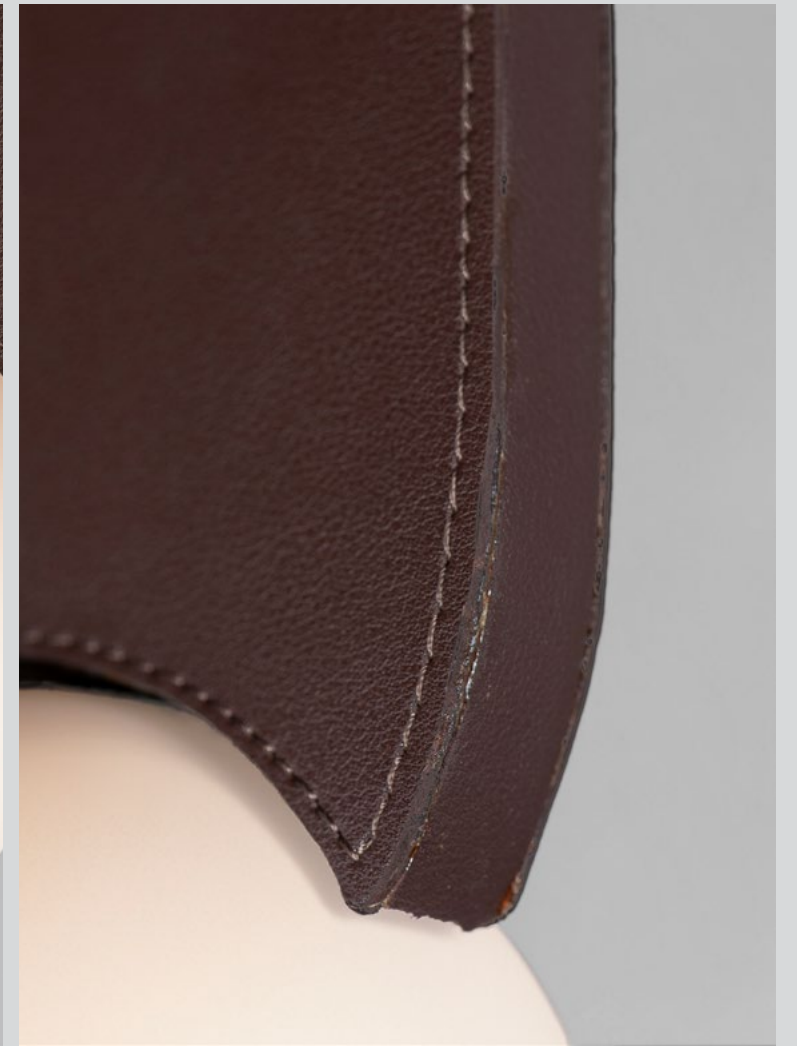



SM24602



SM24603



SM24601



SM24600

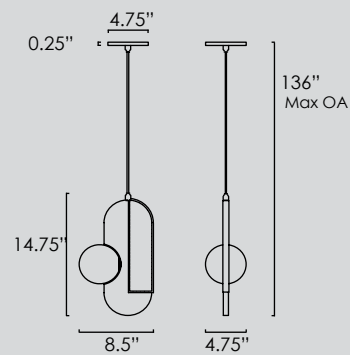

SM24602 • Side-Light Pendant

(1) 4W LED PCB (Included)  
8.5"W x 14.75"H x 4.75"L, 136" Max OA  
Canopy: 4.75"D x 0.25"H  
3000K, CRI 90+, 350 lm

Available in Dark Brown Leather with  
Brushed Bronze (BBZ)

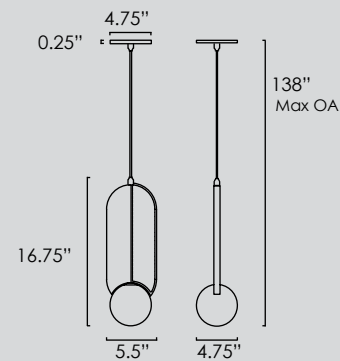

SM24603 • Down-Light Pendant

(1) 4W LED G9 PCB (Included)  
4.75"W x 16.75"H x 5.5"L, 138" Max OA  
Canopy: 4.75"W x 0.25"H  
3000K, CRI 90+, 350 lm

Available in Dark Brown Leather with  
Brushed Bronze (BBZ)

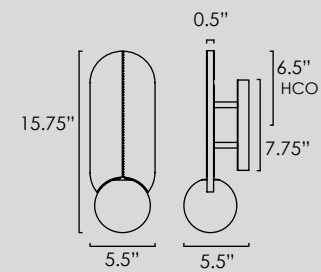

SM24601 • Down-Light Wall Sconce

(1) 4W LED PCB (Included)  
5.5"W x 15.75"H x 5.75"E  
BP: 4.75"W x 7.75"H, 6.5" HCO  
3000K, CRI 90+, 350 lm

Available in Dark Brown Leather with  
Brushed Bronze (BBZ)

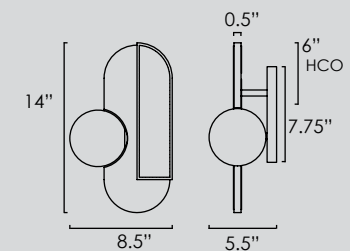

SM24600 • Side-Light Wall Sconce

(1) 4W LED PCB (Included)  
8.5"W x 14"H x 5.5"E  
BP: 4.75"W x 7.75"H, 6" HCO  
3000K, CRI 90+, 350 lm

Available in Dark Brown Leather with  
Brushed Bronze (BBZ)





**STITCHED**  
MADE TO  
ORDER

Expertly fabricated metalwork constructed to support artisan craft leather work in Dark Brown tones. Configured to illuminate orbs of light supported at various positions, the white glass spheres cast ambient light from the included LED lamps diffused within. The hand applied Brushed Bronze finish compliments the luxurious, genuine Dark Brown leather creating a warm soft modern lighting product. Conspicuously joined together around the frame's center, the leather features eye-catching saddle stitching. An exercise in master craftsmanship, the Stitched Collection presents a playful, yet handsomely casual lighting collection that agrees with both modern and transitional aesthetics.

**Canopies**

|                  |  |                                  |
|------------------|--|----------------------------------|
| 5 Port (SM24605) | (5) 4W G9 LED 3000K 1600 lm 90+ (Included) | 13.75"W x 16"H x 48"L, 138"MaxOA |
| 6 Port (SM24608) | (8) 4W G9 LED 3000K 2500 lm 90+ (Included) | 16.25"W x 16"H x 72"L, 138"MaxOA |

**Pendants**

Side-Light Pendant (SMP24602)  
Down-Light Pendant (SMP24603)

**Available Finish**

Dark Brown Leather w/ Brushed Bronze (BBZ)





# DREAMER

Drawing inspiration from her acclaimed "Dreamcloud" experiential design at Art Basel Miami, Nina Magon reinterprets her otherworldly installation for use in the home or hospitality project. The exaggerated curve, definitive of Magon's lighting design, suspends iridescent bubble-like glass forms that appear to float across channels of LED illumination. Available in Heritage Brass and Gunmetal finishes, this Dreamer pairs perfectly with coordinating finishes in the Nina Magon lighting collection.



SM24934

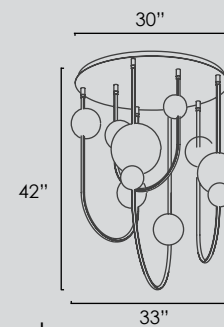

SM24934 • 42" Flush Mount

84.5W LED DC (integrated)  
33"D x 42"H  
Canopy: 30"D x 1.25"H  
3000K, CRI 90+, 3040 lm

Available in Iridescent w/ Natural Aged Brass (IRNAB)  
Mirrored Smoke w/Black Chrome (MSKBC)







SM24938

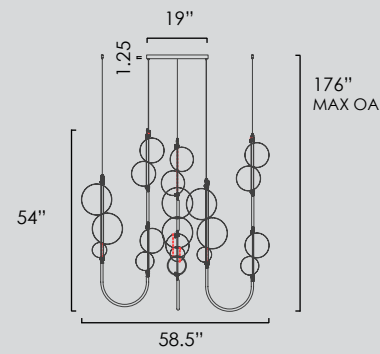

SM24938 • Chandelier

54W LED DC (integrated)  
58.5"D x 54"H, 176" Max OA  
Canopy: 19"D x 1.25"H  
3000K, CRI 90+, 2160 lm

Available in Iridescent w/ Natural Aged Brass (IRNAB)  
Mirrored Smoke w/Black Chrome (MSKBC)



SM24936

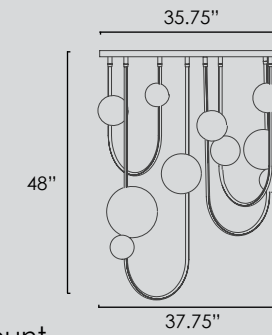

SM24936 • 48" Flush Mount

85W LED DC (integrated)  
20"W x 48"H x 37.75"L  
Canopy: 19"W x 1.25"H x 35.75"L  
3000K, CRI 90+, 3120 lm

Available in Iridescent w/ Natural Aged Brass (IRNAB)  
Mirrored Smoke w/Black Chrome (MSKBC)





SM24930

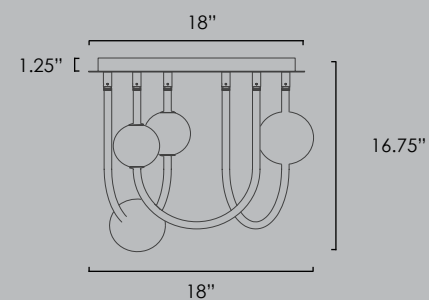

SM24930 • Flush Mount

33W LED DC (integrated)  
 18"D x 16.75"H  
 Canopy: 18"D x 1.25"H  
 3000K, CRI 90+, 1200 lm

Available in Iridescent w/ Natural Aged Brass (IRNAB)  
 Mirrored Smoke w/Black Chrome (MSKBC)



SM24929

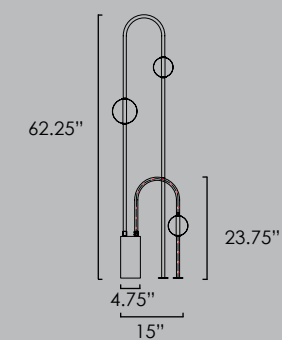

SM24929 • Floor Lamp

12W LED DC (integrated)  
 6"W x 62.25"H x 15"L  
 Base: 4.75"W x 9.75"D  
 3000K, CRI 90+, 480 lm

Available in Iridescent w/ Natural Aged Brass (IRNAB)  
 Mirrored Smoke w/Black Chrome (MSKBC)





# ALINA

Seemingly limber arms in French Gold are dotted with glowing white glass spheres illuminated by dedicated LED light sources. As if 14K Gold bangles with pearl accents are transformed into a lighting fixture that whimsically glows as they float from thin stems, the Alina Collection manifests the concept that lighting is the jewelry of the room.

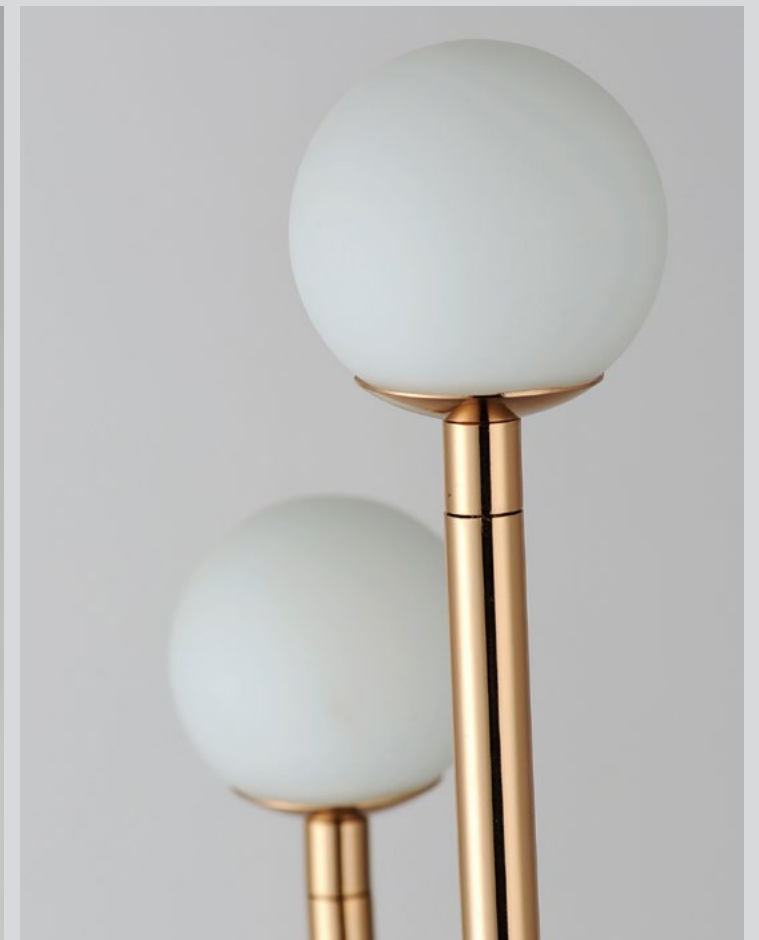



SM24836



SM24833



SM24830

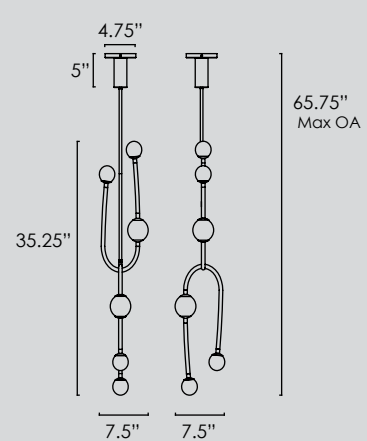

SM24836 • Pendant

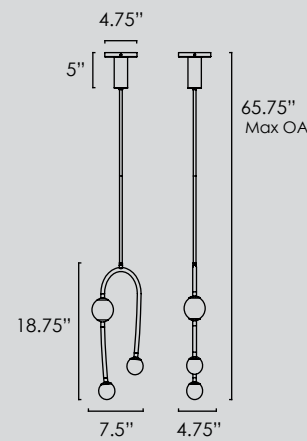

SM24833 • Pendant

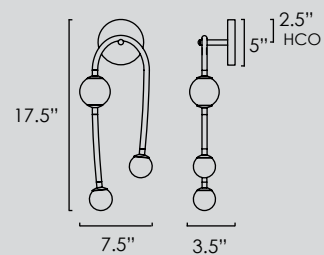

SM24830 • Sconce

(6) .6W LED PCB (integrated)  
7.5"W x 35.25"H x 7.5"L, 65.75"Max OA  
Canopy: 4.75"D x 5"H  
3000K, CRI 80+, 620 lm

(3) .6W LED PCB (integrated)  
4.75"W x 18.75"H x 7.5"L, 65.75"Max OA  
Canopy: 4.75"D x 5"H  
3000K, CRI 80+, 310 lm

(3) .6W LED PCB (integrated)  
7.5"W x 17.5"H x 3.5"E  
BP: 4.75"D x 5"H  
3000K, CRI 80+, 310 lm

Available in French Gold (FG)  
Matte Black (BK)

Available in French Gold (FG)  
Matte Black (BK)

Available in French Gold (FG)  
Matte Black (BK)





# ZEPPELIN

Encased in a brilliantly metallic cage, the Zeppelin showcases airy shapes of precision cut glass with angular details as if illuminated jewelry. The framework cage is finished in either a timeless Heritage Brass or sleek Polished Gunmetal so that this collection complements both modern and traditional settings. Dedicated LED downlights are recessed within the frame to provide additional functional light, while LED lamps are included to highlight the etched details of the suspended glass work.





SM24841

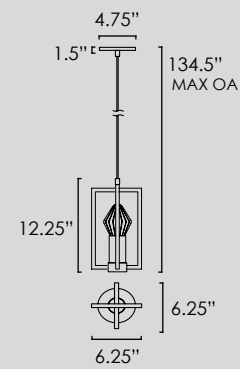

SM24841 • Mini Pendant

2.5W MR11 and 11W LED PCB (int.)  
6.25"D x 12.25"H, 134.5" Max OA  
Canopy: 4.75"W x 1.5"H  
3000K, CRI 80+, 370 lm

Available in Polished Gunmetal (GM)  
Heritage Brass (HR)



SM24843

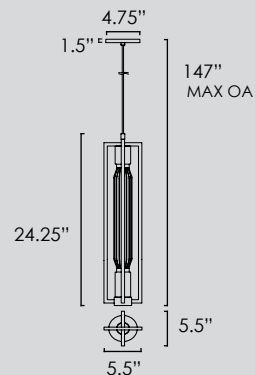

SM24843 • Single Pendant

5W MR11 and 11W LED PCB (int.)  
5.5"D x 24.25"H, 147" Max OA  
Canopy: 4.75"W x 1.5"H  
3000K, CRI 80+, 480 lm

Available in Polished Gunmetal (GM)  
Heritage Brass (HR)



SM24848

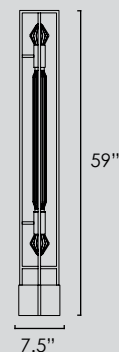

SM24848 • Floor Lamp

11.5W LED MR11 (integrated)  
7.5"W x 59"H x 7.5"L  
3000K, CRI 90+, 640 lm

Available in Polished Gunmetal (GM)  
Heritage Brass (HR)



SM24849

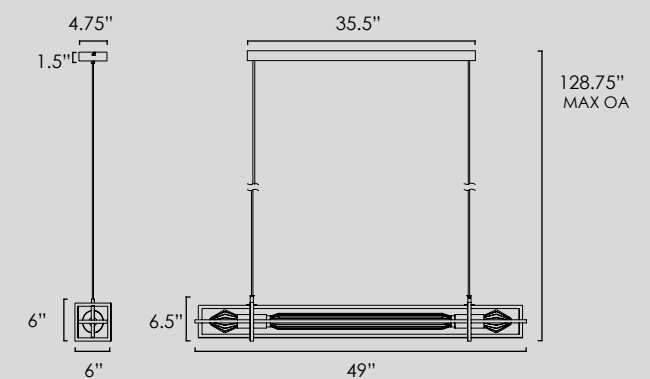

SM24849 • Linear Pendant

22W MR11 and LED PCB (integrated)  
6"W x 6.5"H x 49"L, 128.75" Max OA  
Canopy: 4.75"W x 1.5"H x 35.5"L  
3000K, CRI 80+, 990 lm

Available in Polished Gunmetal (GM)  
Heritage Brass (HR)



# DOLCE VITA

Immerse yourself in luxury delivered by Nina Magon Studio. Faceted crystal charms are linked together as if jewels. Indulge in the Dolce Vita, where a concept so decadent can be a feature in your space. The modular configurations allow you to install the fixture per your space with both remote and surface mounted canopy structures. Available in Polished Chrome or Natural Aged Brass.



SM24869 • 180"

70W LED DC (integ.)  
3.25"W x 180"L  
Canopy: 6"D x 0.25"H  
3000K, CRI 90+, 4200 lm

SM24868 • 132"

48W LED DC (integ.)  
3.25"W x 132"L  
Canopy: 6"D x 0.25"H  
3000K, CRI 90+, 2880 lm

SM24867 • 108"

45W LED DC (integ.)  
3.25"W x 108"L  
Canopy: 6"D x 0.25"H  
3000K, CRI 90+, 2700 lm

SM24866 • 84"

30W LED DC (integ.)  
3.25"W x 84"L  
Canopy: 6"D x 0.25"H  
3000K, CRI 90+, 1800 lm

Available in Beveled Crystal in either Gold (BCGLD) or Polished Nickel (BCPN)



SM24862

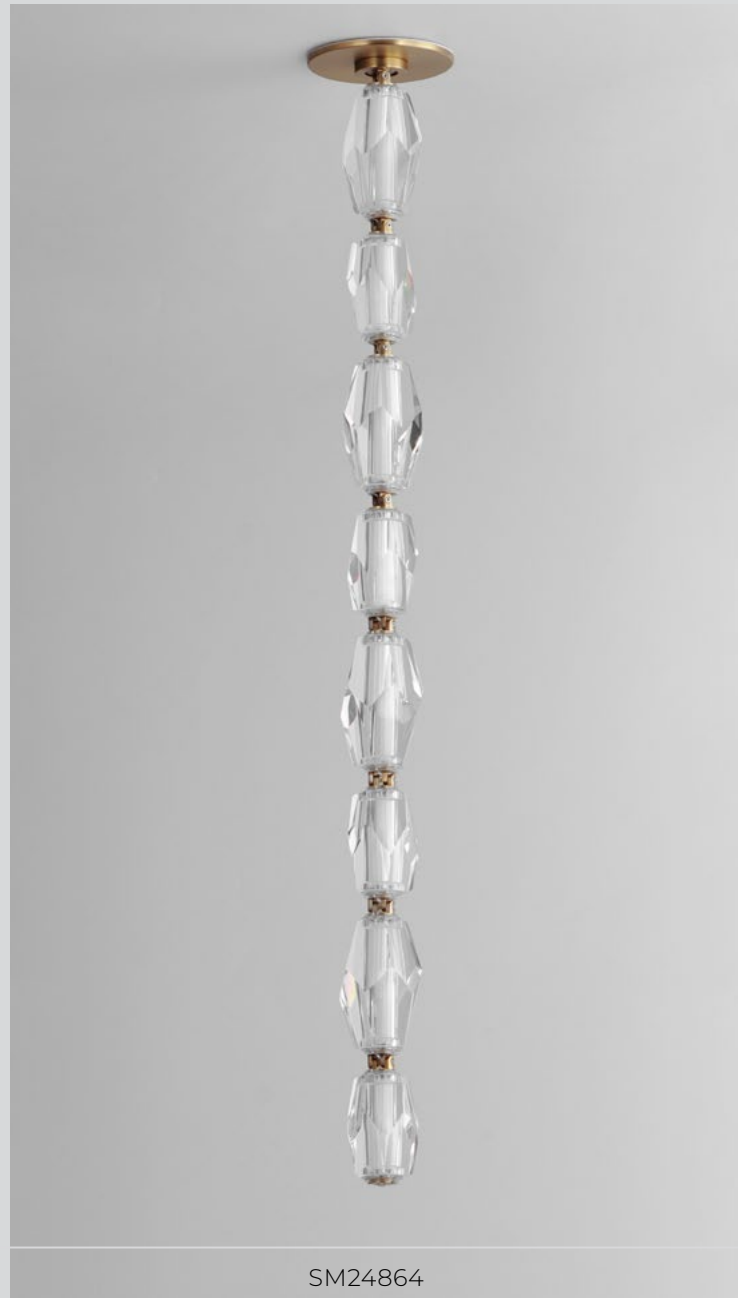

SM24864

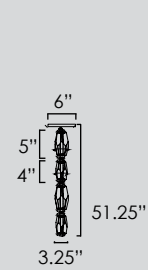

SM21300 • Single Sconce

12W LED DC (integrated)  
3.25"D x 24"L  
Canopy: 6"D x 0.25"H  
3000K, CRI 90+, 5720 lm

Available in Beveled Crystal in either Gold (BCGLD) or Polished Nickel (BCPN)

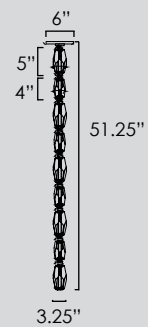

SM24864 • Single Pendant

20W LED DC (integrated)  
3.25"D x 48"L  
Canopy: 6"D x 0.25"H  
3000K, CRI 90+, 5720 lm

Available in Beveled Crystal in either Gold (BCGLD) or Polished Nickel (BCPN)



SM24861

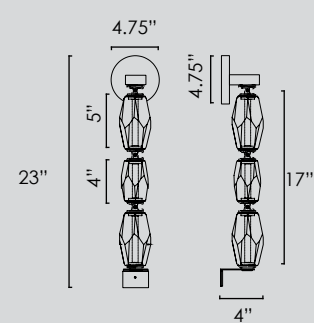

SM24861 • Sconce

9W LED DC (integrated)  
3.24"W x 23"H x 4"E  
BP: 4.75"W x 4.75"H, 2" HCO  
3000K, CRI 90+, 400 lm

Available in Beveled Crystal in either Gold (BCGLD) or Polished Nickel (BCPN)



SM24863

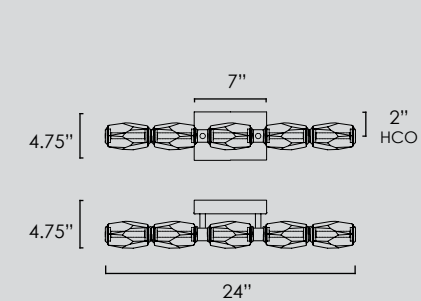

SM24863 • 24" Sconce

15W LED DC (integrated)  
4.75"W x 24"H x 4.75"E  
BP: 7"L x 1.5"H, 2" HCO  
3000K, CRI 90+, 790 lm

Available in Beveled Crystal in either Gold (BCGLD) or Polished Nickel (BCPN)



SM24865

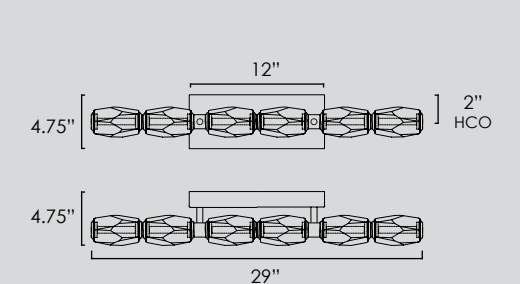

SM24865 • 30" Sconce

15W LED DC (integrated)  
4.75"W x 29"H, 4.75"E  
BP: 12"L x 1.5"H, 2" HCO  
3000K, CRI 90+, 1030 lm

Available in Beveled Crystal in either Gold (BCGLD) or Polished Nickel (BCPN)





# MEDALLION

Classic diamond facets were the concept behind the facets of the crystal shades in round or baguette rectangular frames. Just like a Medallion, they can be installed on the wall with ADA compliant extensions or onto your ceiling adding opulence to your space. The indirect LED light source is sealed within an irregularly faceted diffuser and a polished back plate creates a dazzling reflective display. Frames are finished in burnished Gold with a neutral, warm 3000k color temperature.



SM24851



SM24853

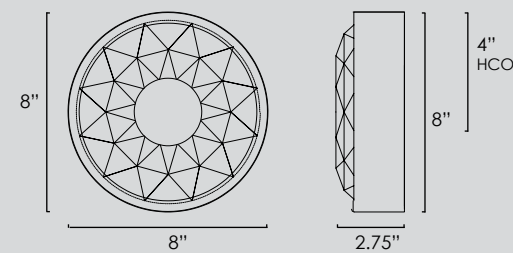

SM24851 • Round Sconce

10W LED PCB (integrated)  
 8"D x 2.75"E  
 BP: 8"D, 4" HCO  
 3000K, CRI 90+, 360 lm

Available in Gold with Beveled Crystal (BCGLD)

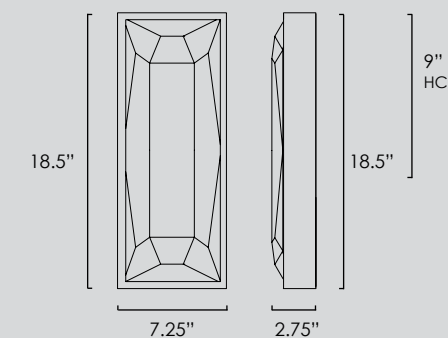

SM24853 • Wall Sconce

32W LED PCB (integrated)  
 7.25"W x 18.5"H x 2.75"E  
 BP: 7.25"W x 18.5"H, 9" HCO  
 3000K, CRI 90+, 740 lm

Available in Gold with Beveled Crystal (BCGLD)



# STRATUM

Clear slabs of glass a half inch thick are pressed together between two discs finished in Natural Aged Brass. As the glass approaches the center, each slab of glass increases in dimension creating a gradation of light revealing the glasses' shape and character. Dedicated LED lighting emits from concealed polycarbonate tubes evenly distributing the light source in all directions. These LED tubes terminate at brass discs supported by Dark Brown leather straps that both suspend the pendants and conceal the electrical wiring stitched within them. Elevate your lighting to the next Stratum integrating bygone modern design elements with innovative technologies and expert craftsmanship.



SM24406

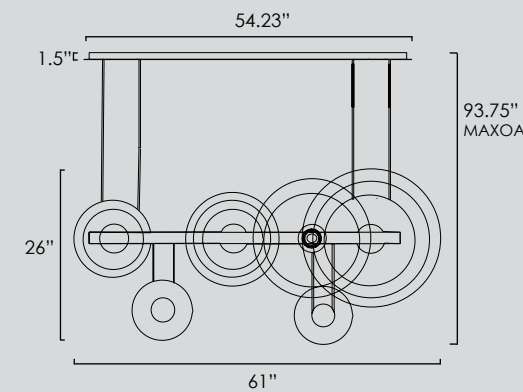

SM24406 • Chandelier

65W LED DC (integrated)  
 8.25"W x 26"H x 61"L, 93.75" Max OA  
 Canopy: 6"W x 1.5"H x 54.25"L  
 3000K, CRI 90+, 2400 lm

Available in Clear with Natural Aged Brass (CLNAB)





SM24402



SM24401



SM24400

ADA

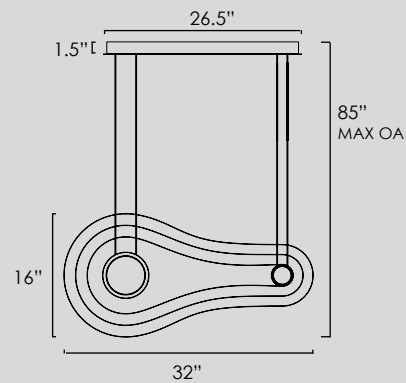

SM24402 • Pendant

30W LED PCB(integrated)  
4"W x 16"H x 32"L, 85" Max OA  
Canopy: 6.25"W x 1.5"H x 26.5"L  
3000K, CRI 90+, 1100 lm

Available in Clear with Natural Aged Brass (CLNAB)

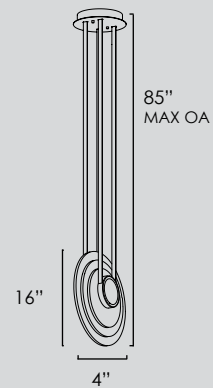

SM24401 • Pendant

16W LED PCB (integrated)  
4"W x 16"H x 16"L, 85"Max OA  
Canopy: 6.25"W x 1.25"H x 8.75"L  
3000K, CRI 90+, 600 lm

Available in Clear with Natural Aged Brass (CLNAB)

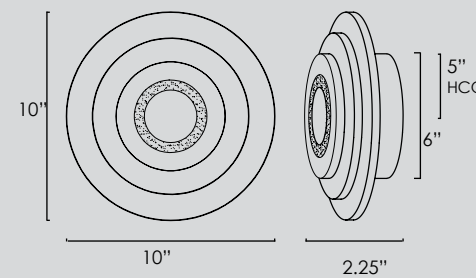

SM24400 • Sconce/ Flush

8W LED PCB (integrated)  
10"W x 10"H x 2.25"E  
BP: 6"W x 1"H x 6"L  
3000K, CRI 90+, 320 lm

Available in Clear with Natural Aged Brass (CLNAB)





# ARYA

Double stacked hand-blown glass domes plateau to a flattened plane resting marvelously on a cylindrical tube striped with dedicated LED light reveals. Glass options of Mirror Smoked or an opulent Emerald Green pair with a second clear glass shade. They appear to float as they suspend on the cylinders finished in fine French Gold or Polished Black Nickel. At the end of the cylinder an additional downlight provides functional lighting below.

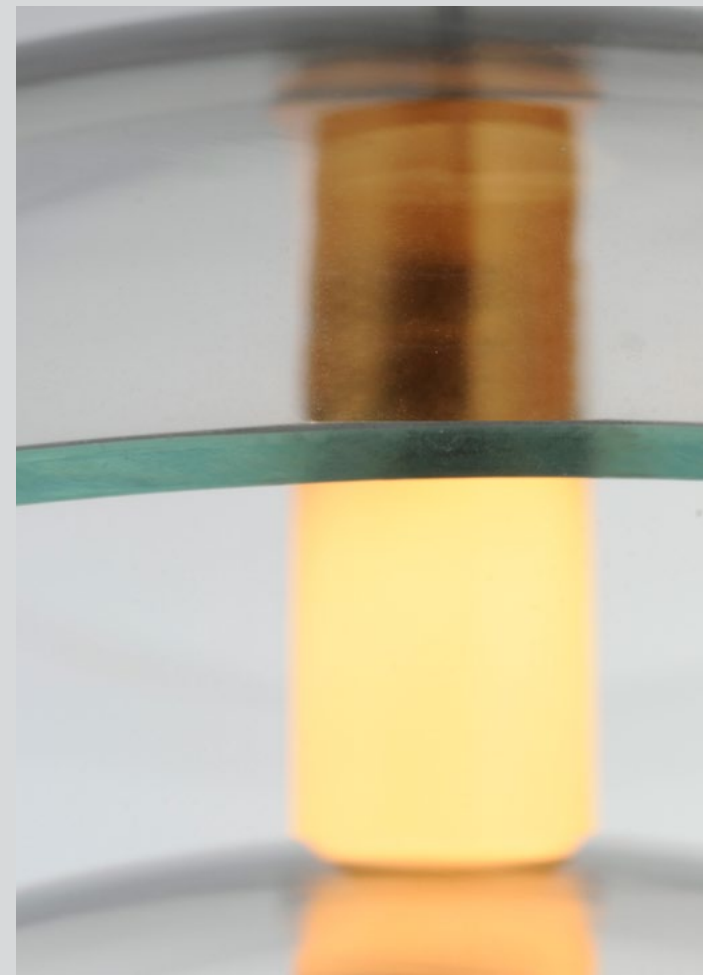
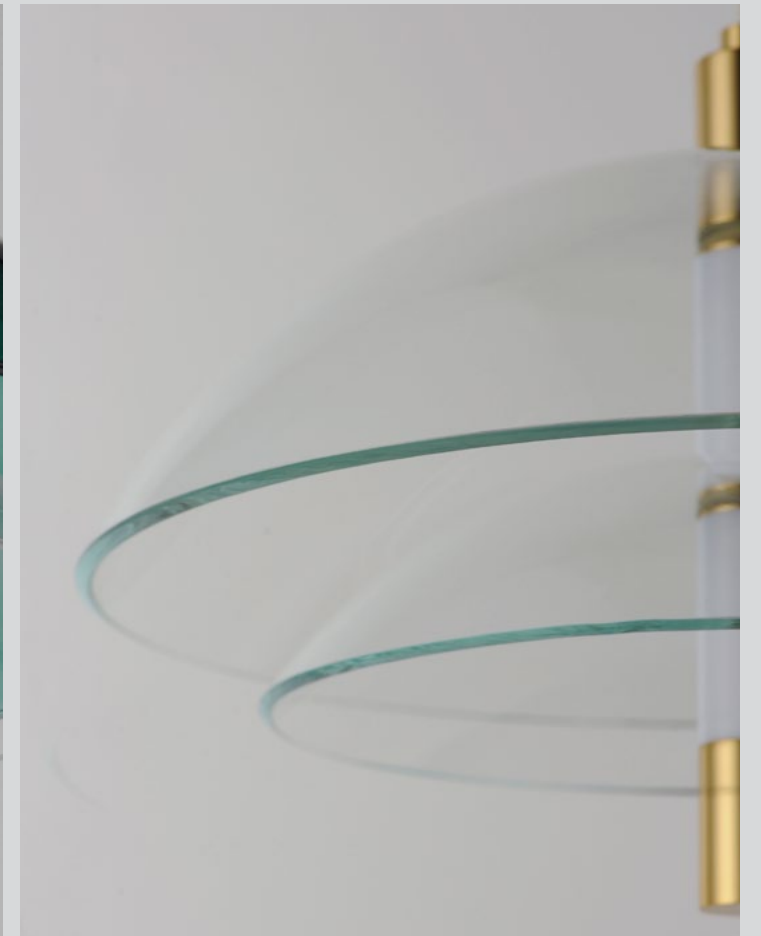



SM24701

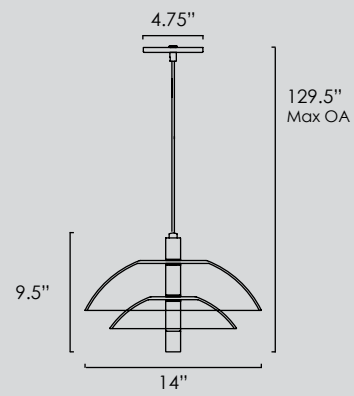

SM24701 • Pendant

(2)5W LED PCB (integrated)  
14"W x 9.5"H x 14"L, 129.5" Max AO  
Canopy: 4.75"W x 0.5"H  
3000K, CRI 90+, 300 lm

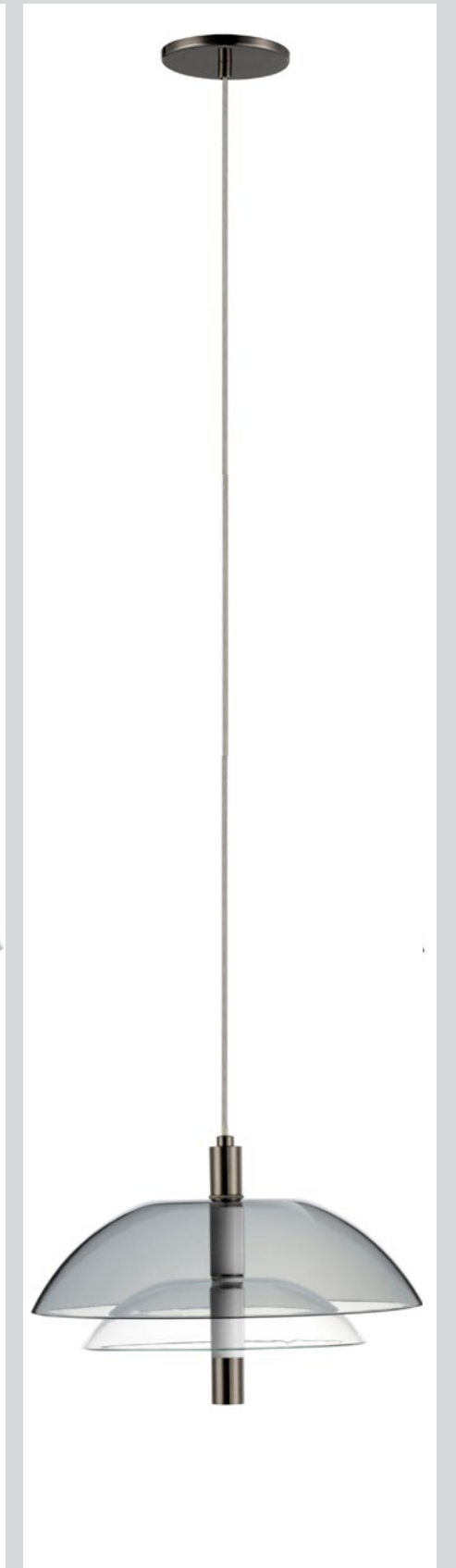
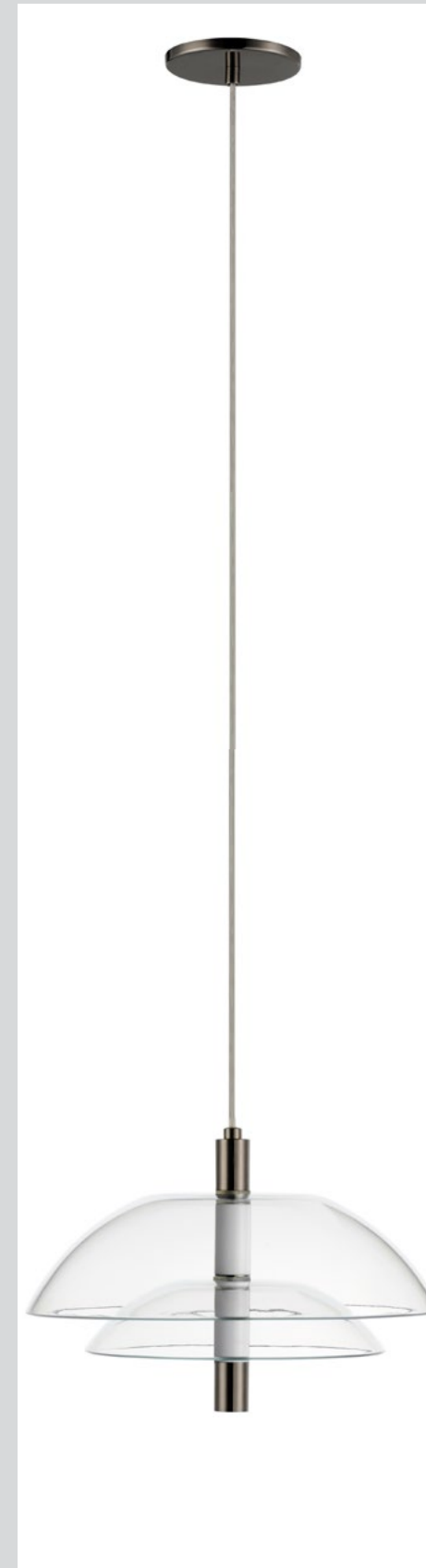

Available in Clear with French Gold (CLFG)  
Clear with Black Nickel (CLBC)  
Emerald Green/ Clear with French Gold (GECLFG)  
Smoke/Clear with Black Nickel (MSCLBC)



# MEGALITH

A monument to the beauty of stone, the Megalith collection is constructed using a robust iron stem that branches off to support various panel options. These various elliptical panels are back lit with globes of white cased glass. Choose from stone panels sets including Spanish Alabaster, a pleasantly pink Rose Jade, White Onyx or a breathtaking Striae Arya with dramatic veining and dark grey color tone. The enduring appeal of the stone's character boosts the luxurious nature of this design. The framework is available in Gunmetal, Brushed Bronze or Heritage Brass and made to order configurations for quick modifications. For a more modern, futuristic approach to the design, the Megalith collection is also offered in a retro dichroic glass option.





SM24811



SM24812

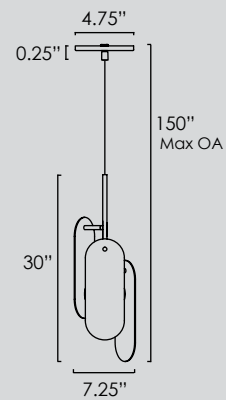
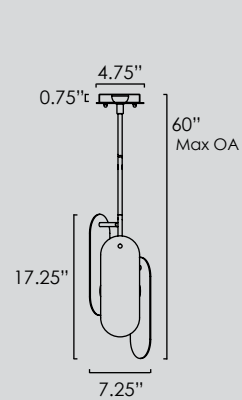
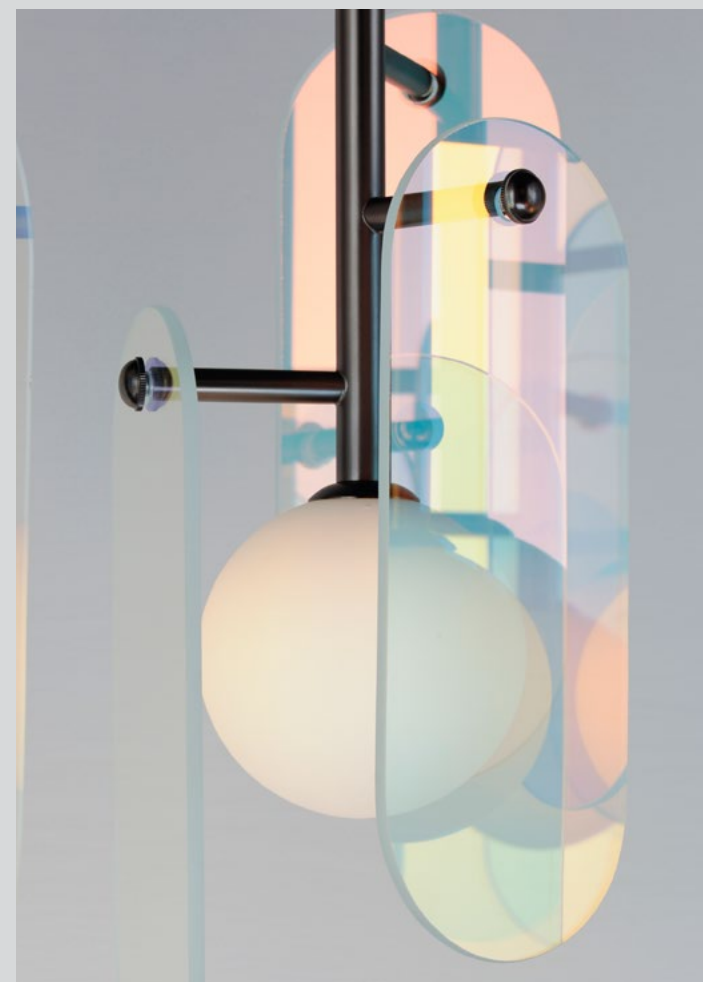

SM24811 • Stem Hung Pendant

SM24812 • Cord Hung Pendant

(1) 4W LED G9 (Included)  
7.25"D x 17.25"H, 60" Max OA  
Canopy: 4.75"D x 0.75"H  
3000K, CRI 90+, 350 lm

(1) 4W LED G9 (Included)  
7.25"D x 30"H, 150" Max OA  
Canopy: 4.75"D x 0.25"H  
3000K, CRI 90+, 400 lm

**Available Finishes**

- Brushed Bronze (BBZ)
- Gunmetal (GM)
- Heritage Brass (HR)

**Panel Options**

- Spanish Alabaster (WA)
- White Onyx (OX)
- Rose Jade (RJ)
- Striae Arya (ARY)
- Dichroic glass (DC)
- Amber Glass (AM)
- Mirror Smoke (MSK)
- Various Stone (VS)

*\*Various Stone* is a mixture of Striae Arya, Rose Jade and Alabaster



SM24827



SM24825



**MEGALITH  
MADE TO  
ORDER**

Make Nina Magon's Megalith pendants your own! Select the canopy, finish and stone or glass panels desired on a cord-hung pendant kit. Reach out to your sale representative or Studio M concierge to configure your custom Megalith design.

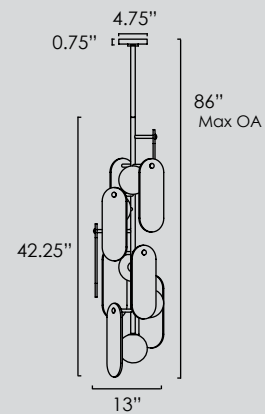

SM24827 • Vertical Pendant

(5) 4W LED G9 (Included)  
13"W x 42.25"H x 13"L, 86" MAX OA  
Canopy: 4.75"D, 0.75"H  
3000K, CRI 90+, 350 lm

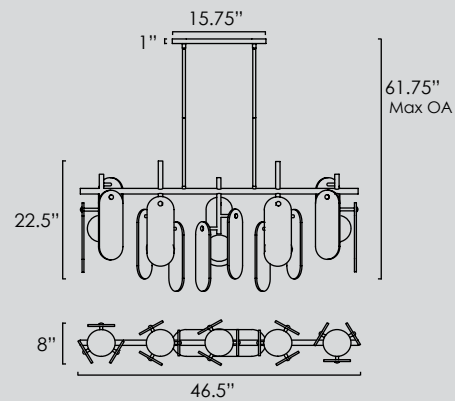

SM24825 • Linear Pendant

(5) 4W LED G9 (Included)  
8"W x 22.5"H x 46.5"L, 61.75" MaxOA  
Canopy: 4.75"W x 15.75"L x 1"H  
3000K, CRI 90+, 1400 lm

**Available Finishes**

- Brushed Bronze (BBZ)
- Gunmetal (GM)
- Heritage Brass (HR)

**Panel Options**

- Spanish Alabaster (WA)
- White Onyx (OX)
- Rose Jade (RJ)
- Striae Arya (ARY)
- Dichroic glass (DC)
- Amber Glass (AM)
- Mirror Smoke (MSK)
- Various Stone (VS)

\*Various Stone is a mixture of Striae Arya, Rose Jade and Alabaster

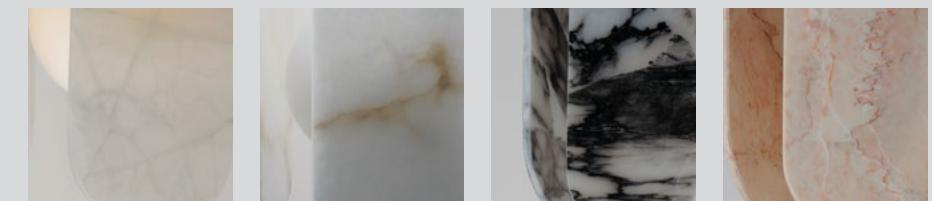

White Onyx

Alabaster

Striae Arya

Rose Jade

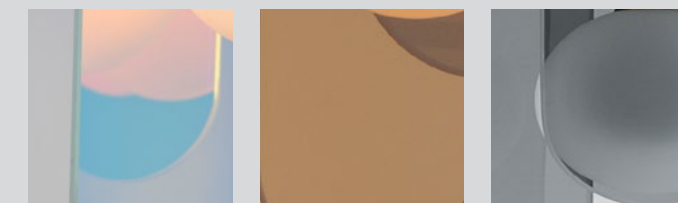

Dichroic Glass

Amber Glass

Mirror Smoke

**Available Finishes**

- Brushed Bronze (BBZ)
- Gunmetal (GM)
- Heritage Brass (HR)

**Panel Options**

- Spanish Alabaster (WA)
- White Onyx (OX)
- Rose Jade (RJ)
- Striae Arya (ARY)
- Dichroic glass (DC)
- Amber Glass (AM)
- Mirror Smoke (MSK)

\*Various Stone is a mixture of Striae Arya, Rose Jade and Alabaster

**Canopy Options**

- 5 Port Round (SM24815) 13.75"W x 30"H x 48"L, 151" Max OA
- 8 Port Round (SMC1008) 16.25"W x 30"H x 72"L, 151" Max OA

**Lamping Options**

- 3000K 4W LED G9 90+ CRI
- 4000K 4W LED G9 90+ CRI





SM24810

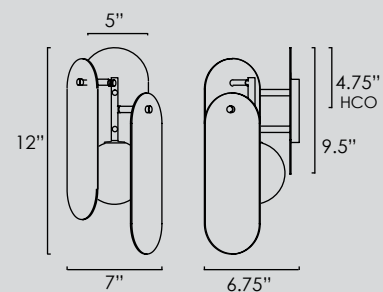
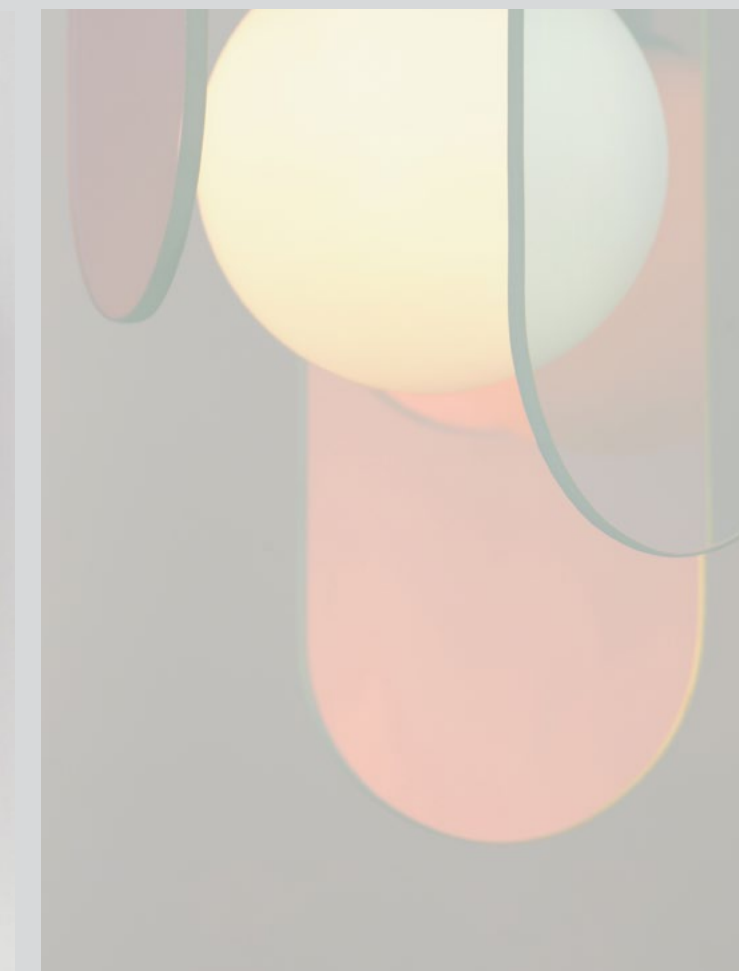

**Available Finishes**

- Brushed Bronze (BBZ)
- Gunmetal (GM)
- Heritage Brass (HR)

**Panel Options**

- Spanish Alabaster (WA)
- White Onyx (OX)
- Rose Jade (RJ)
- Striae Arya (ARY)
- Dichroic glass (DC)
- Amber Glass (AM)
- Mirror Smoke (MSK)

SM24810 • Sconce

(1) 4W LED G9 (included)  
 7"W x 15.5"H x 6.75"E  
 BP: 5"W x 9.5"H, 4.75" HCO  
 3000K, CRI 90+, 450 lm



# STONEWALL

Complimentary wall lighting products display the unique beauty of Spanish Alabaster and our Striae Arya stone panels in a modern application. Low-profile ADA sconce options in alabaster as well as illuminated mirrors and wall decor pair perfectly with the Megalith collection or stand alone to enhance a room's décor.



SM24800

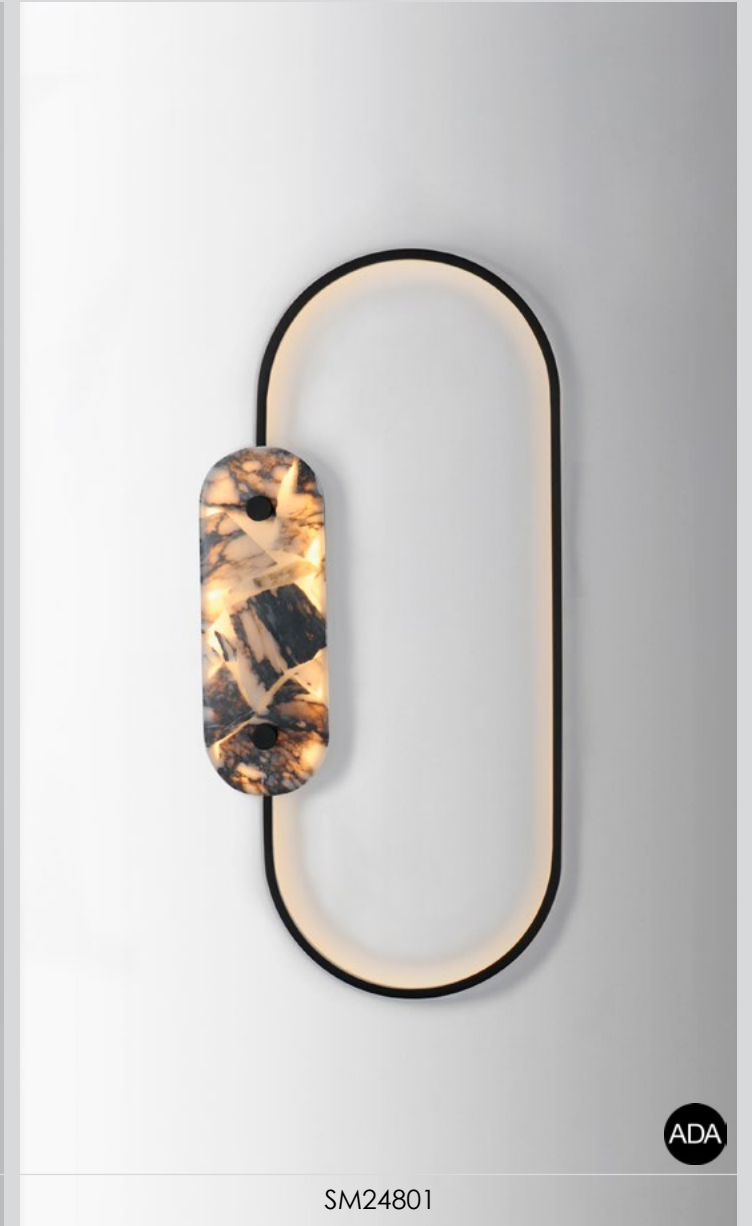

SM24801

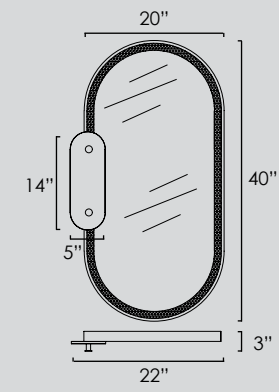

SM24800 • LED Mirror

35W LED PCB (integrated)  
22"W x 40"H x 3"E  
BP: 6"W x 1.25"H x 6"L  
3000K, CRI 90+, 1830 lm

Available in Striae Arya with Black (ARYBK)  
White Alabaster with Black (WABK)

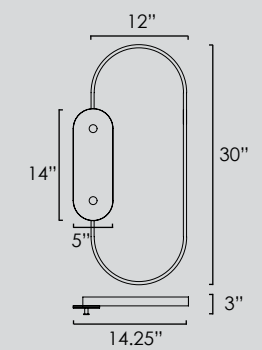

SM24801 • LED Wall Decor

40W LED PCB (integrated)  
14.25"W x 30"H x 3"E  
3000K, CRI 90+, 670 lm

Available in Striae Arya with Black (ARYBK)  
White Alabaster with Black (WABK)



SM24802

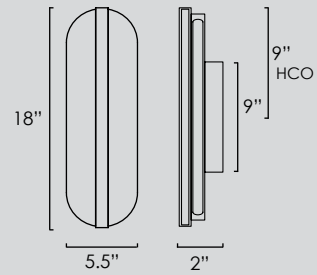

SM24802 • Sconce

15W LED PCB (integrated)  
5.5"W x 18"H x 2"E  
BP: 4.75"W x 9"L x 9 HCO  
3000K, CRI 90+, 750 lm

Available in Striae Arya with Black (ARYBK)  
White Alabaster with Heritage Brass (WABCN)

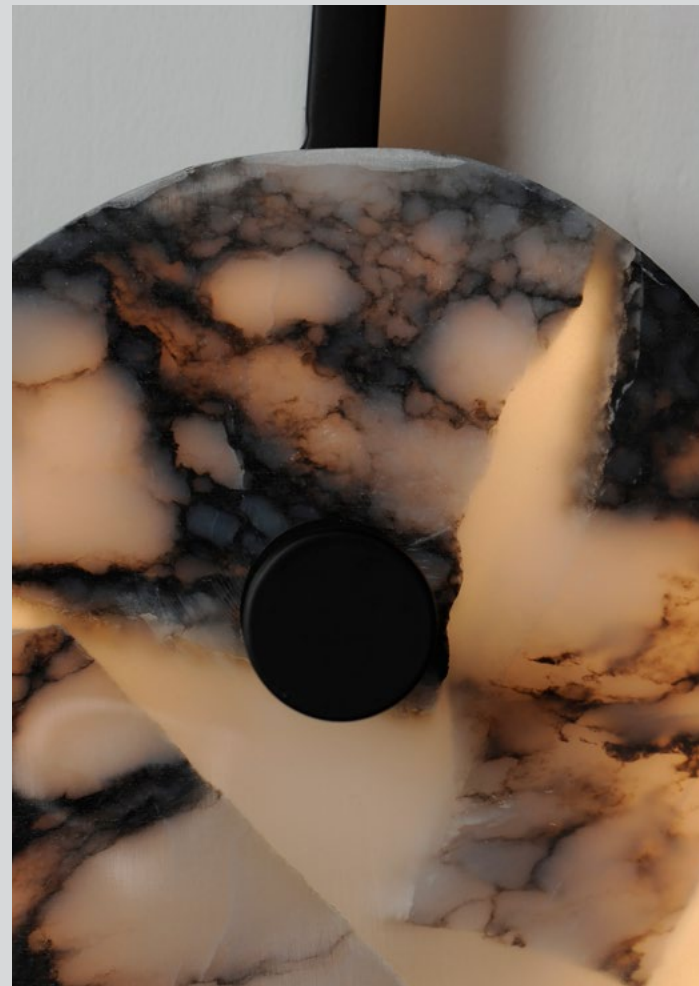
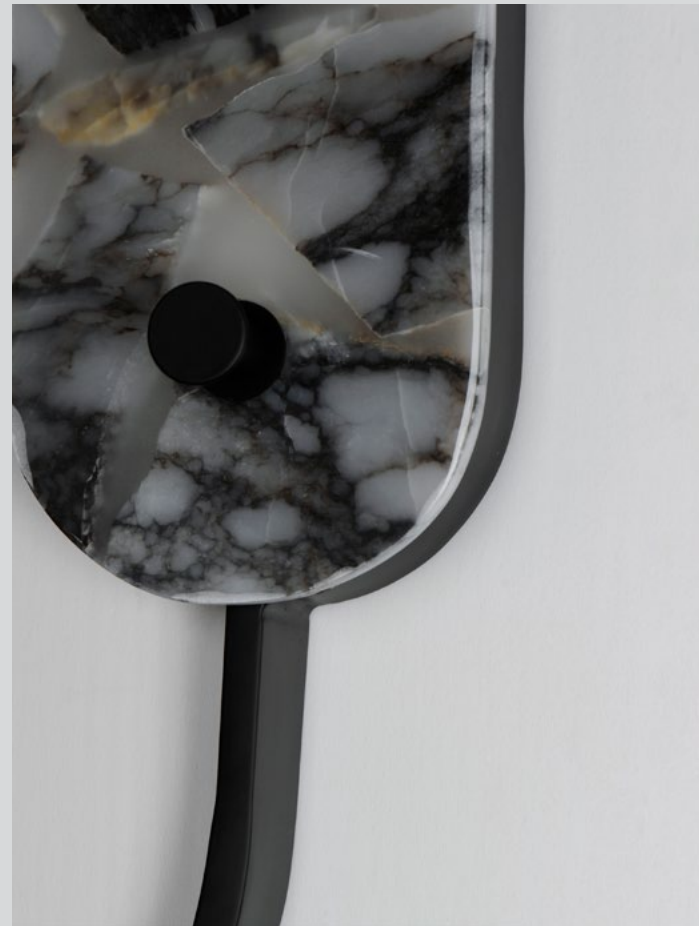



SM2421

**NEW AGE**  
Desk Lamp

In an approach distinctly found in the works of Nina Magon, the New Age portable desk lamp presents a familiar, yet unusual shape is made up of combined elements with sophisticated allure. A curved slab of brushed metal in Gunmetal or Bronze are feature a notched space showcase somewhat translucent natural stone works. Choose from a combination of Brushed Gunmetal with our recycled glass and marble composite, Straie Arya, or Brushed Bronze with Spanish Alabaster for warm neutral aesthetic. These portable lamps feature 3-step touch dimming technology and LED lamps provided softly diffused by the signature white glass globe shades.

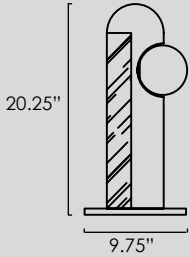

SM2421 • Accent Light

(1) 4W LED G9 PCB (included)  
6"W x 20.25"H x 9.75"L  
3000K, CRI 90+, 350 lm

Available in Brushed Bronze with Alabaster (WABBZ)  
Brushed Gunmetal with Straie Arya (ARYBGM)





SM2441

**HOURGLASS**  
Desk Lamp

A polished mix of materials in a stylishly geometric accent lamp come together in the Hopper Accent Lamp by Nina Magon. The base is fabricated out of a mass of Black marble while it's inversely resting cone shade is constructed of Polished Rose Gold stainless steel. The joint where the base and shade meet allows you to direct the light source to your discretion. Striking in its form, the Hopper exemplifies the mingling of fashion, culture, and design in a product.

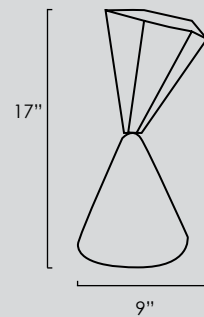

SM2441 • Accent Light

(1) 9W LED E26 (included)  
9"W x 17"H x 9"L  
3000K, CRI 90+, 650 lm

Available in Rose Gold with Black Marble (RGBK)



SM2431

**SATELLITE**  
Accent Lamp

A bold dish of French Gold reflects the glow of Satin White Opal White glass shades that softly diffuse LED lamps provided. The globe shade rests on a solid mass of exquisitely veined Black marble. The combination offers a delightful combination of elements in a restrained, yet sophisticated accent lamp.

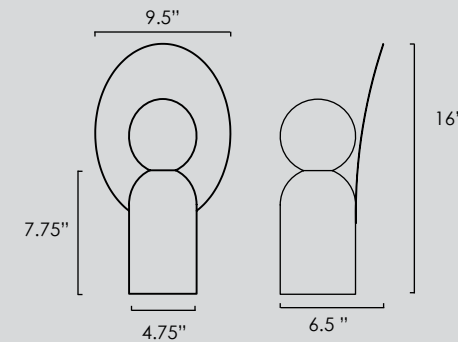

SM2431 • Accent Light

(1) 4W LED G9 PCB (included)  
4.75"W x 16"H x 9.5"L  
3000K, CRI 90+, 350 lm

Available in French Gold with Black Marble (FGBK)

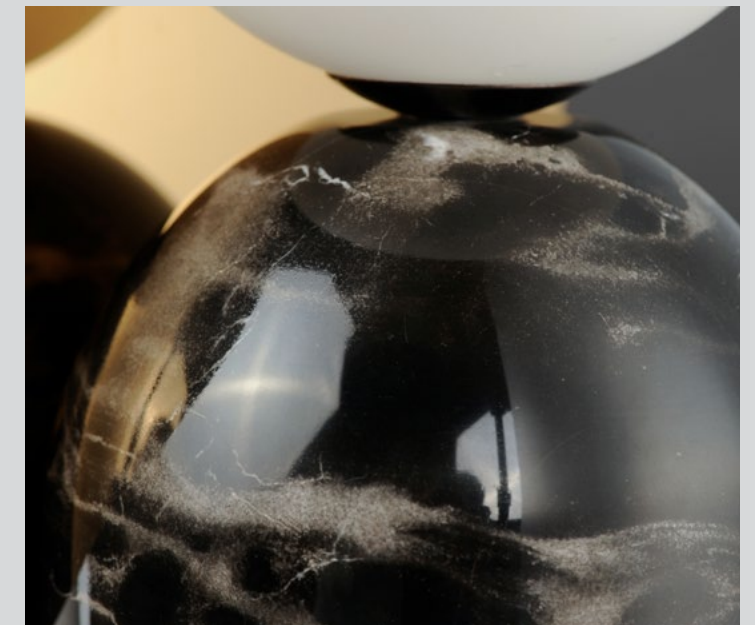

# MAT SANDERS

## métissage

MASCULINE NOUN

*le métissage de la société; the cultural mix of society*

With reference to the brasseries of Paris, the gentlemen clubs of English high society, and the design concepts of Scandinavian minimalism and Mid Century Italian masters, Mat Sanders presents a refreshingly retro vision of lighting products. Defined by his California Casual aesthetic, Mat reveals his cultivated taste of vintage products updated by an expert minimalist restraint. The result is the following collection created in collaboration with Studio M demonstrating a vision of lighting that attractively mixes modern playful forms with warm color tones and materials that suits traditional and modern environments.



# CHAPEAU

Cheerful in design, the Chapeau nods its domed cap at the brasseries of Paris with updates inspired by Dutch modern trends. Contemporary Satin Brass metalwork contrasts with wrapped leather accents that terminate at a translucent glass dome and globe glass shade. The globe of opal Satin White glass softly diffuses LED lamps provided and accentuates the round forms of the outer Clear shade. The products are secured with knurled locking mechanisms that add industrial flair representative of Mat Sanders. Combining contrasting materials with pop appeal, the Chapeau collection offers large scale wall sconces that playfully curve out from the wall and practical pendants with matching accents.





SM21303

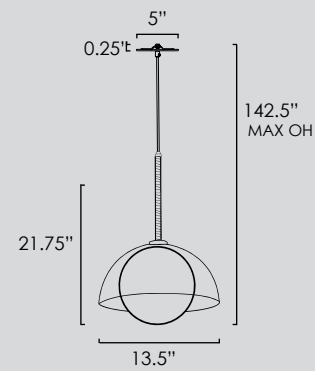

SM21303 • Pendant

9W LED E26 (included)  
 13.5"W x 21.75"H x 13.5"L, 142.5" Max OA  
 Canopy: 5"W x 0.25"H x 5"L  
 3000K, CRI 90+, 700 lm



Available in White Leather with Satin Brass (SBR)



SM21300

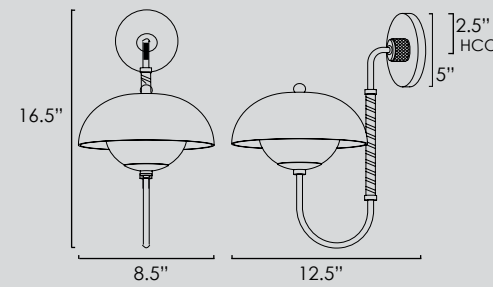

SM21300 • Sconce

4W LED G9 PCB (included)  
 8.5"W x 16.5"H x 12.5"E  
 BP: 5"W x 0.75"H x 5"L  
 3000K, CRI 90+, 300 lm

Available in White Leather with Satin Brass (SBR)



SM21301

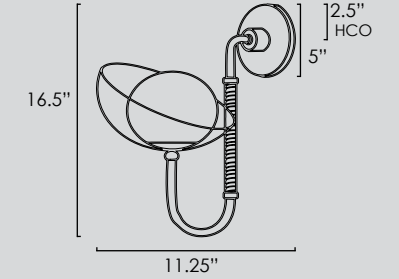

SM21301 • Sconce

4W LED G9 PCB (included)  
 8.5"W x 16.5"H x 11.25"E  
 BP: 5"W x 0.75"H x 5"L  
 3000K, CRI 90+, 300 lm

Available in White Leather with Satin Brass (SBR)





# CHIPS

Thinly curved panels of perforated metal shades are illuminated by LED globes of Satin White glass at various positions along the span of the suspended chip-like sculptures. The expansiveness of the panels are voluminous, yet seemingly airy in their perforated translucence. Influenced by pop art and sculpture, the Chips are functional lighting products comically named to express some of the personality in Mat Sanders' designs. The collection includes large scale pendants vertically or horizontally suspended, smaller scaled single pendants, and wall sconces. The shade panels are available in Natural Aged Brass and 'Mat' White, but they can also be manufactured in RAL finishes chosen by Mat Sanders like a more dramatic hues of Dark Slate and 'Mat Black'. Make it monochromatic or combine the finishes to create an illuminated art piece that matches your space.

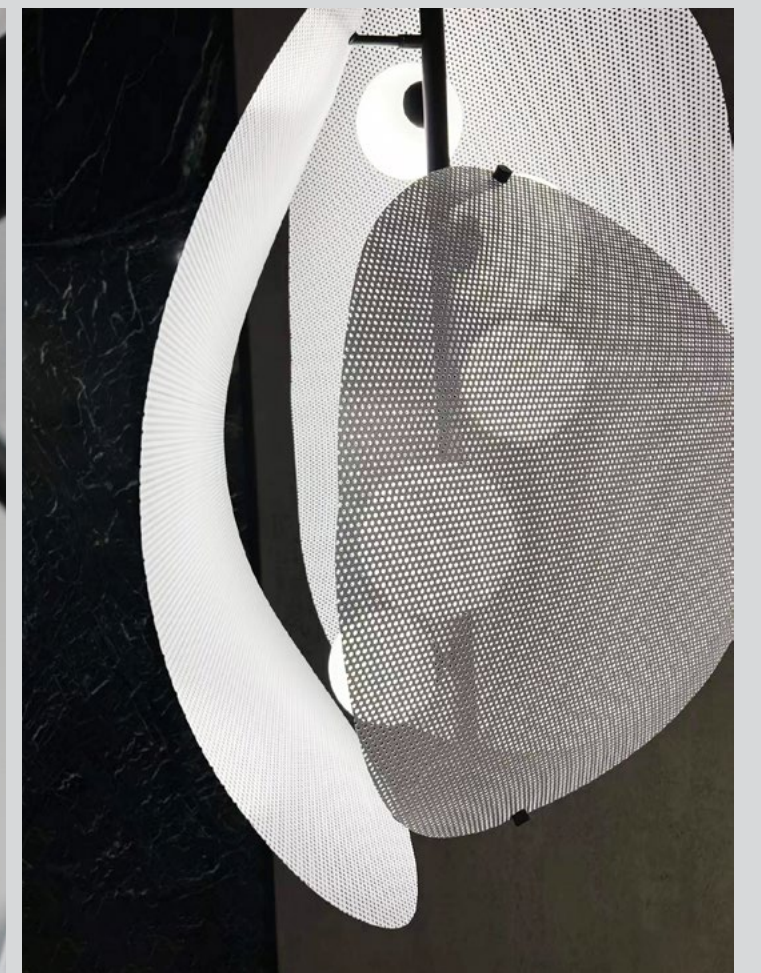
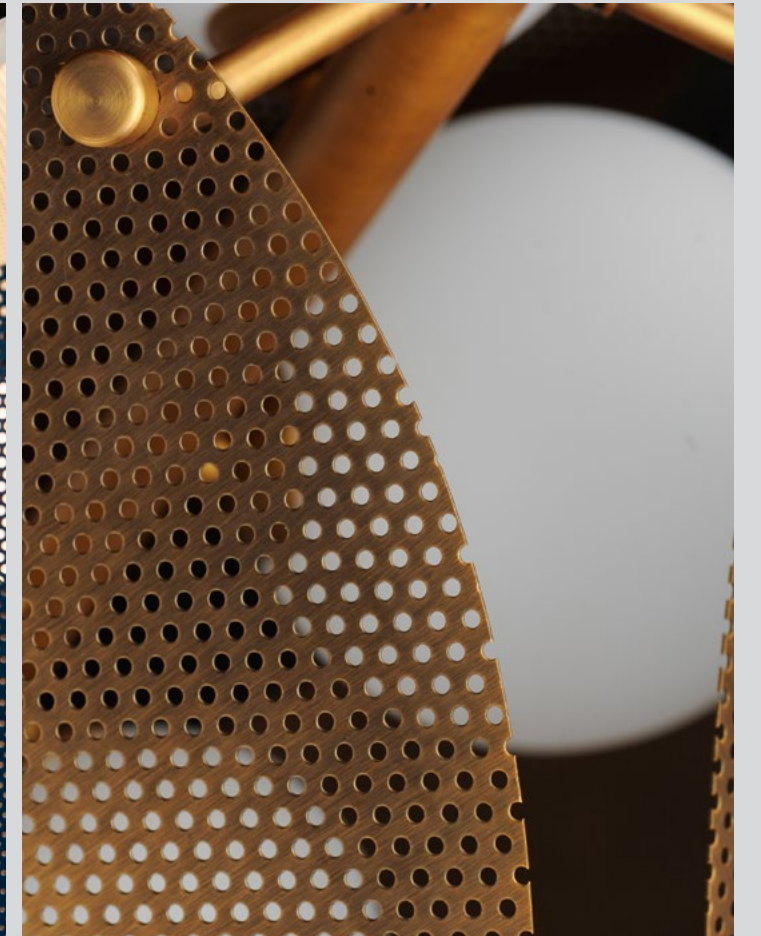
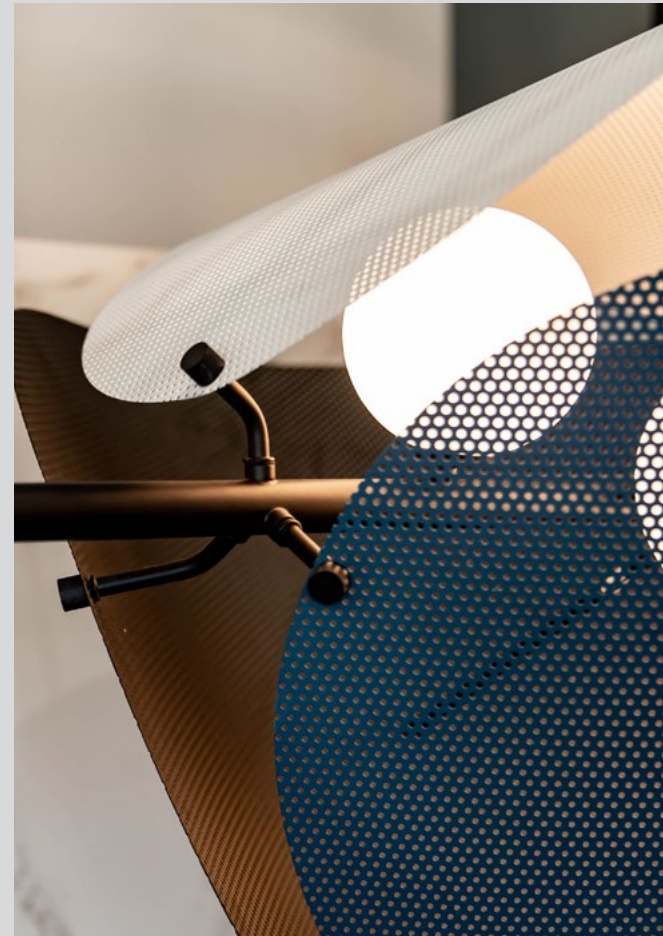



SM32305



SM32303

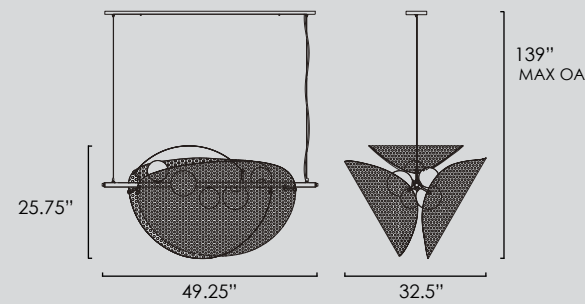





SM32305 • Linear Pendant

(5) 4W LED G9 PCB (included)  
 32.5"W x 25.75"H x 49.25"L, 139" Max OA  
 Canopy: 4.75"W x 0.755"H x 48"L  
 3000K, CRI 90+, 1575 lm

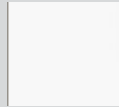
Available in Natural Aged Brass (SWNAB)  
 'Mat' White (SWMW)

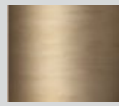
**Customize Your Panels**

|   |                           |
|---|---------------------------|
|  | 'Mat' White (MW)          |
|  | *Mat' Black (BK)          |
|  | *Natural Aged Brass (NAB) |
|  | Dark Slate Grey (DG)      |

\* Frame comes in choice of Natural Aged Brass or 'Mat' Black

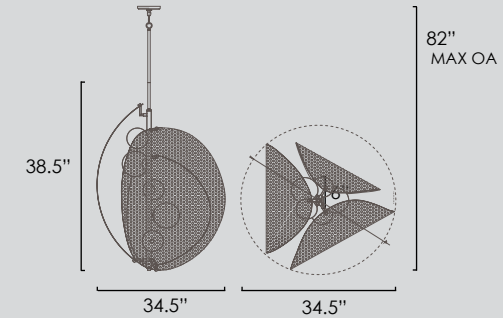



SM32303 • Vertical Pendant

(5) 4W LED G9 PCB (included)  
 34.5"W x 38.5"H, 82" Max OA  
 Canopy: 5"W x 0.75"H  
 3000K, CRI 90+, 1575 lm

Available in Natural Aged Brass (SWNAB)  
 'Mat' White (SWMW)

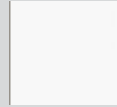
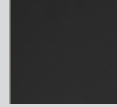
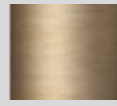
**Customize Your Panels**

|   |                           |
|---|---------------------------|
|  | 'Mat' White (MW)          |
|  | *Mat' Black (BK)          |
|  | *Natural Aged Brass (NAB) |
|  | Dark Slate Grey (DG)      |

\* Frame comes in choice of Natural Aged Brass or 'Mat' Black



SM32361

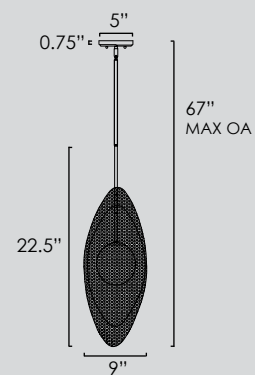



SM32361 • Pendant

(1) 4W LED G9 PCB (included)  
 9"W x 22.5"H x 8.25"L, 67" Max OA  
 Canopy: 5"W x 0.75"H  
 3000K, CRI 90+, 325 lm

Available in Natural Aged Brass (SWNAB)  
 'Mat' White (SWMW)

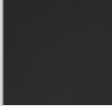
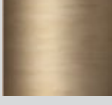
**Customize Your Panels**

-  'Mat' White (MW)
-  \*'Mat' Black (BK)
-  \*Natural Aged Brass (NAB)
-  Dark Slate Grey (DG)

\* Frame comes in choice of Natural Aged Brass or 'Mat' Black



SM32360

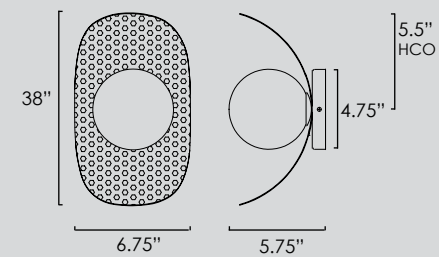

SM24402 • Pendant

(1) 4W LED G9 PCB (included)  
 6.75"W x 11.25"H x 5.75"E  
 BP: 4.75"D x 0.75"H x 5.5"HCO  
 3000K, CRI 90+, 325 lm

Available in Natural Aged Brass (SWNAB)  
 'Mat' White (SWMW)

**Customize Your Panels**

-  'Mat' White (MW)
-  \*'Mat' Black (BK)
-  \*Natural Aged Brass (NAB)
-  Dark Slate Grey (DG)

\* Frame comes in choice of Natural Aged Brass or 'Mat' Black





# DOMAIN

A truncated sphere open at its top and bottom encircles a globe of Opal White glass shades. The outer glass shade is suspended by a strapping structure in complimentary finishes. Select from a combination of finishes that include acid etched Satin White glass with Natural Aged Brass, crystal Clear glass with polished Black Nickel, or a striking Smoke striped Clear glass with matte Gunmetal. On the larger pendants the yoke uses leather stitched detail work adding a new discovery that coordinates with the collection. Complimentary smaller scale pendants and sconces round out this collection presenting applications for multiple applications. The attention to detail and fascinating combination of elements is influenced by the various cultural and period pieces within Mat Sanders' design domain. Synonymous with his casual yet sophisticated aesthetic, the collection includes a variety of lighting types that coordinate with various locations, applications, and finishes.

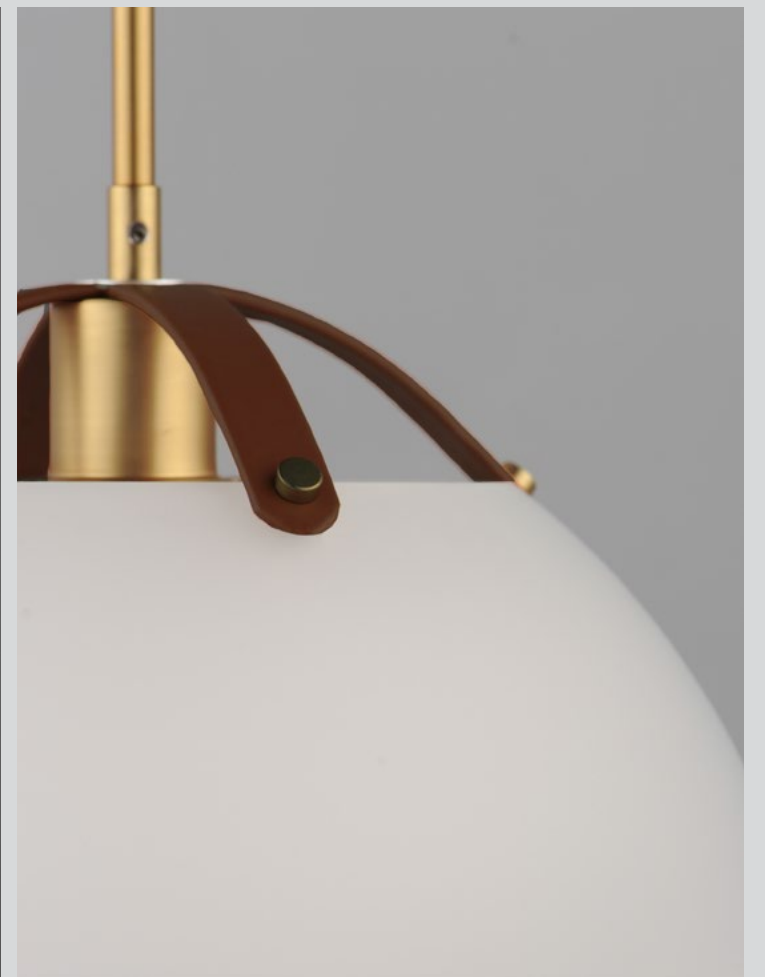
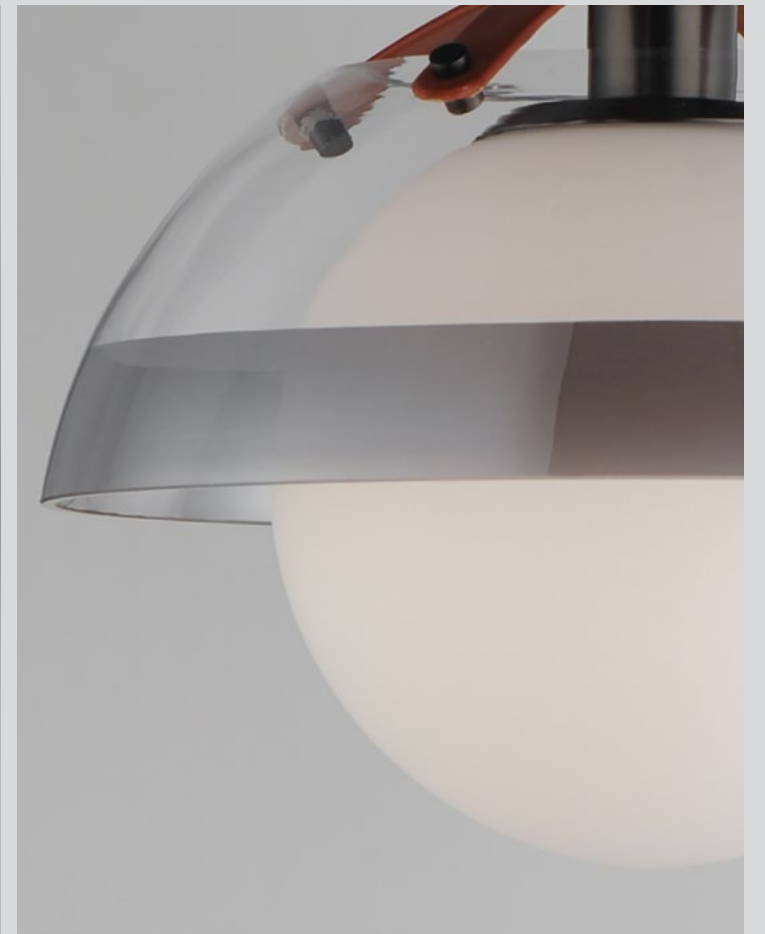



SM31014



SM31012

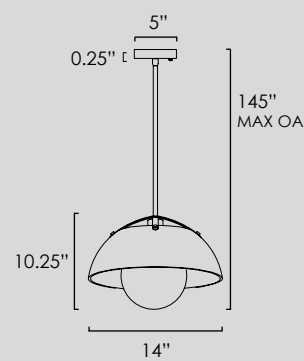

SM31014 • Pendant

(1) 9W E26 LED (included)  
 14W x 10.25"H x 14"L, 145" Max OA  
 Canopy: 5"W x 0.25"H  
 3000K, CRI 90+, 700 lm

Available in Frost / Natural Aged Brass (FTNAB)  
 Smoke Stripe / Gun Metal (MSCLGM)  
 Clear / Chrome (CLPC)

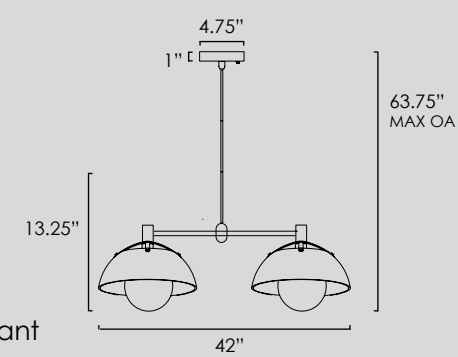

SM31012 • Pendant

(2) 9W E26 LED (included)  
 14"W x 13.25"H x 42"L, 63.75" Max OA  
 Canopy: 4.75"W x 1"H, 4.75"L  
 3000K CRI 90+, 1400 lm

Available in Frost / Natural Aged Brass (FTNAB)  
 Smoke Stripe / Gun Metal (MSCLGM)  
 Clear / Chrome (CLPC)





SM31009

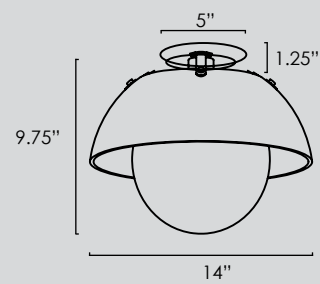

SM31009 • Flush Mount

(1) 9W E26 LED (included)  
14"W x 9.75"H x 14"L  
Canopy: 5"D x 1.25"H  
3000K, CRI 80+, 700 lm

Available in Frost / Natural Aged Brass (FTNAB)  
Smoke Stripe / Gun Metal (MSCLGM)  
Clear / Chrome (CLPC)



SM31001



SM31002



SM31003



**Shade Option**

- Frosted Glass (FT)
- Clear Glass (CL)
- Mirrored Glass (MSK)

**Available Finishes**

- Natural Aged Brass (NAB)
- Gun metal (GM)
- Matte Black (BK)
- Polished Chrome (PC)

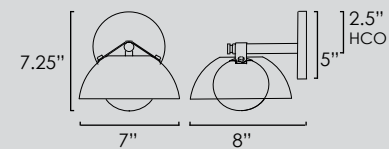

SM31001 • Sconce

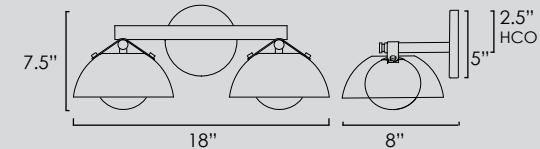

SM31002 • Bath Vanity

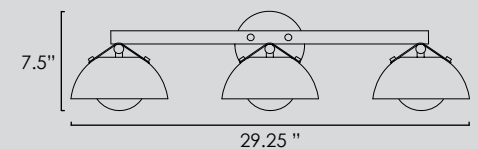

SM31003 • Bath Vanity

(1) 4W G9 LED (included)  
7\"/>

(2) 4W G9 LED (included)  
18\"/>

(3) 4W G9 LED (included)  
29.25\"/>



# INCOGNITO

Ominous glows of LED illuminated glass spheres appear behind glass shades that are opaque when not lit. These deformed sphere shapes of glass are purposely oblong and available in either Mirror plated glass or etched Satin White. They are paired with metalwork in Gunmetal or Natural Aged Brass and include lighting that can be mounted as wall sconces or ceiling lights with additional pendant options that feature a filigree cap perforated with retro dot cut-outs.

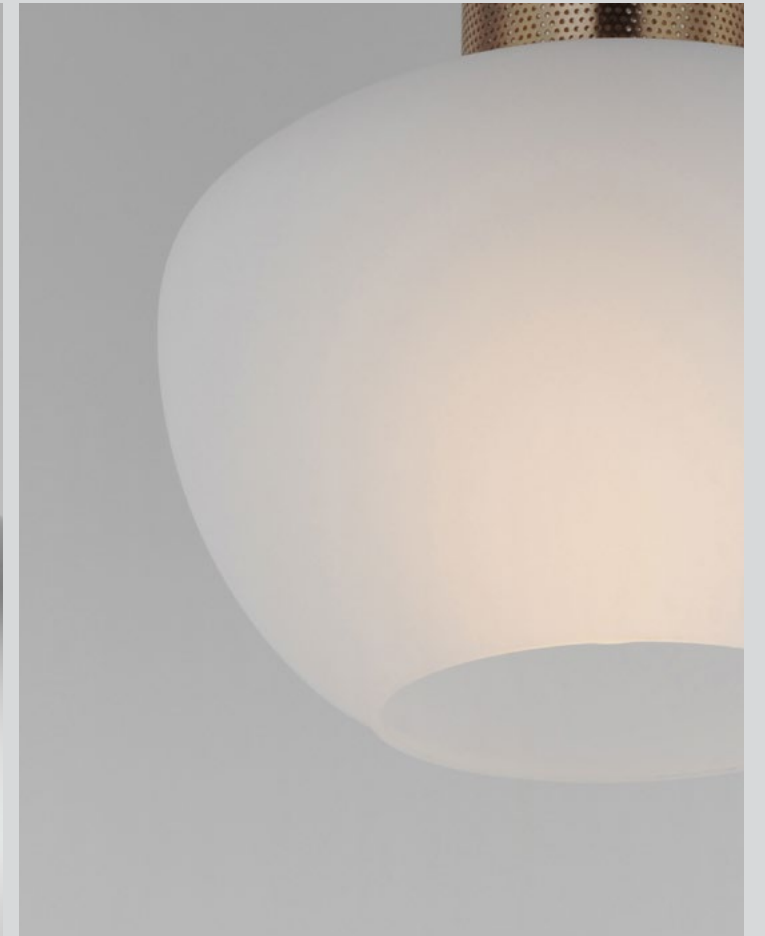





SM31086

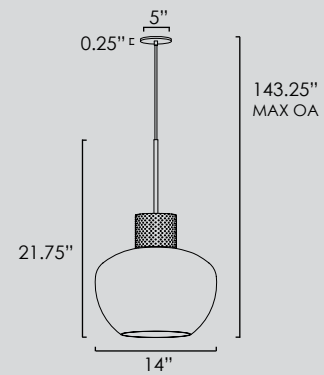

SM31086 • Sconce

(1) 9W E26 LED (included)  
 14"W x 21.75"H x 14 "L, 143.25"Max OA  
 Canopy: 5"W x 0.25"H  
 3000K, CRI 90+, 630 lm

Available in Clear / Chrome (CLPC)  
 Frosted / Heritage Brass (FTHR)  
 Mirror Smoke / Gunmetal (MSKGM)



SM31080

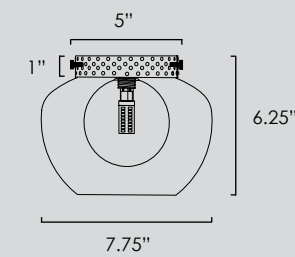

SM31080 • Flush Mount

(1) 4W G9 LED (included)  
 7.75"W x 6.25"H x 7.75"L  
 Canopy: 5"W x 1"H  
 3000K, CRI 90+, 300 lm

Available in Clear / Chrome (CLPC)  
 Frosted / Heritage Brass (FTHR)  
 Mirror Smoke / Gunmetal (MSKGM)



SM31084

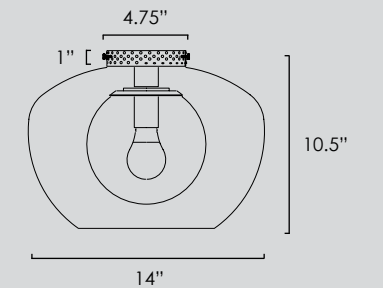

SM31084 • Flush Mount

(1) 9W E26 LED (included)  
 14"W x 10.5"H x 14"L  
 Canopy: 4.75"W x 1"H  
 3000K, CRI 90+, 630 lm

Available in Clear / Chrome (CLPC)  
 Frosted / Heritage Brass (FTHR)  
 Mirror Smoke / Gunmetal (MSKGM)

# CRUX

Crossing planes of ribbed glass panels are asymmetrically arranged along a rod, framed in thin Matte Black iron. The tubular bulbs suspended from various heights are obscured by the glass texture, creating a shimmering show of ambient illumination. The simple circular and arcing shapes are stitched together in an interesting industrial glass texture structure that echoes the internal light patterns. The design, like bound glass and orb lighting pendants, manages to convey retro vibes in a modern, daring, and transitional form.



SM21325

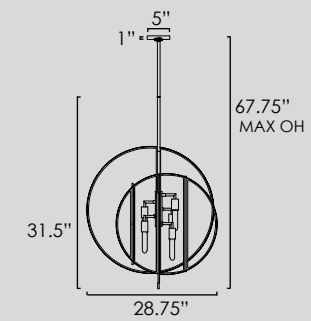

SM21325 • Pendant

(5) 4W E26 Incandescent (included)  
28.75"W x 31.5"H x 25"L, 67.75 MAX OA  
Canopy: 5"W x 1"H  
2700K, CRI 90+, 1000 lm

Available in Clear Ribbed/ Black (CRBK)

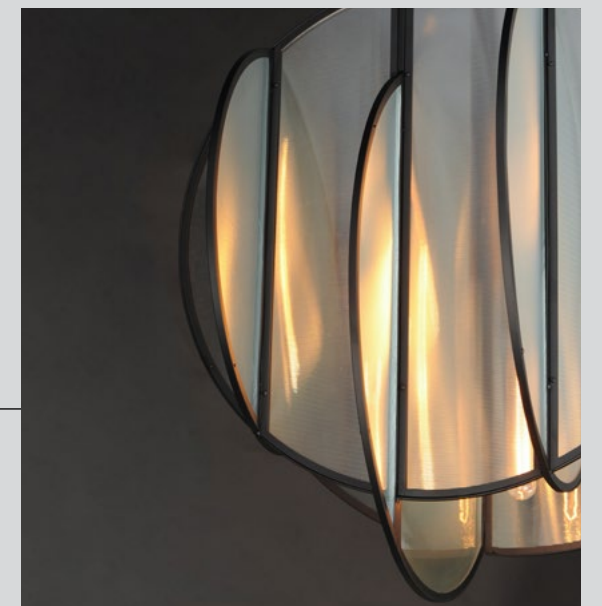

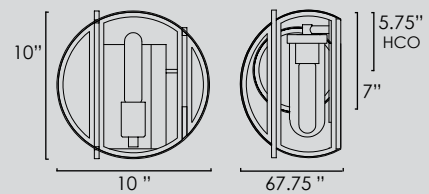
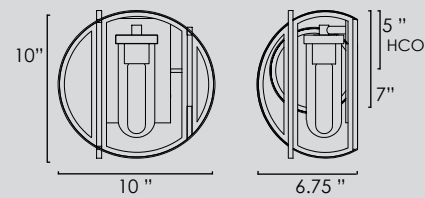

SM21321 • Outdoor Sconce

(1) 4W E26 Incandescent (included)  
 10"W x 10"H x 6.75"E  
 Backplate: 4.5"W x 7"H, 5"HCO  
 2700K, CRI 90+, 140 lm

SM21320 • Sconce

(1) 4W E26 LED (included)  
 10"W x 10"H x 6.75"E  
 Backplate: 4.25"W x 7"H x 5.75" HCO  
 2700K, CRI 90+, 200 lm

Available in Clear Ribbed/ Black (CRBK)

Available in Clear Ribbed/ Black (CRBK)

DIM TO WARM

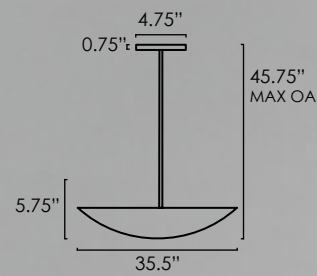

SM81856 • 36" LED Pendant/Semi-Flush

45W LED PCB (integrated)  
 35.5"D x 5.75"H, 45.75" Max OA  
 Canopy: 4.75"D x 0.75"  
 CCT Select 3000-2700-2200K, CRI 90+

Available in Mat White w/ French Gold (MWFG)  
 Black with French Gold (BKFG)  
 French Gold(FG)  
 Polished Chrome(PC)

# VESTA

Symbolic of the hearth and home, the Vesta collection draws inspiration from the Roman goddess represented by the fire of her temple. Large diameters of shallow, inverted vessels disperse indirect light upward scattering softer, ambient light toward the ceiling. Purposeful in design and its applications, a Dim-to-Warm feature is integrated into the LED light engine so that as you set the lighting dimmer past , the light emitted becomes warmer and more relaxing. Highly reflective, polished metal finishes of rich French Gold or cool Polished Chrome elevate the minimalistic forms with vibrancy, while dramatic two-tone options combining "Mat" White or "Mat" Black shades allow for more neutral compositions. Masterfully understated, Mat Sanders manages to create product and spaces that are both effortlessly sophisticated and pleasantly welcoming.



SM81859

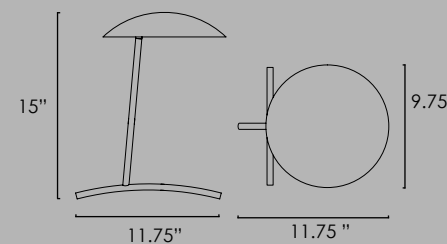

SM81859 • Desk Lamp

20W LED PCB (integrated)  
 9.75"W x 15"H, 11.75"L  
 CCT Select 3000-2700-2200K, CRI 90+

Available in  
 Black with French Gold (BKFG)  
 French Gold(FG)  
 Polished Chrome(PC)



SM81854

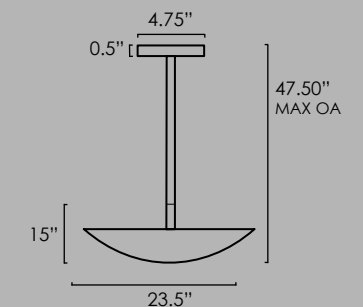

SM81854 • 24" LED Pendant/Semi-Flush

28W LED PCB (integrated)  
 23.5"D x 4.5"H, 47.50" Max OA  
 Canopy: 4.75"D x 0.75"  
 CCT Select 3000-2700-2200K, CRI 90+,

Available in Mat White w/ French Gold (MWFG)  
 Black with French Gold (BKFG)  
 French Gold(FG)  
 Polished Chrome(PC)

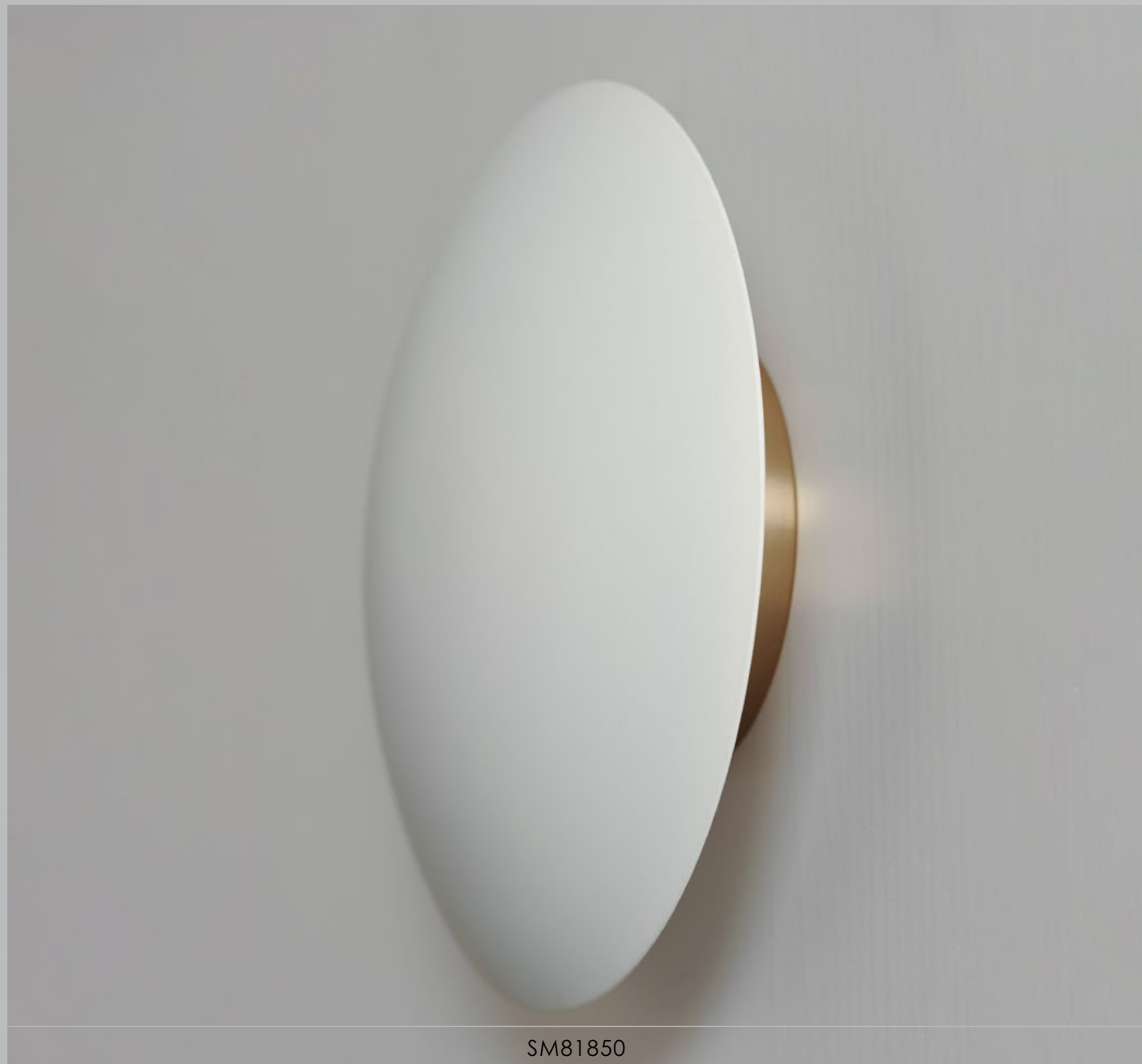

SM81850

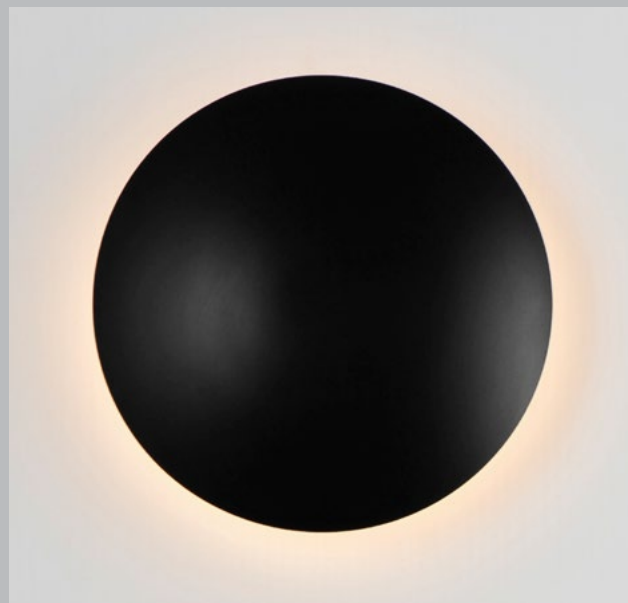
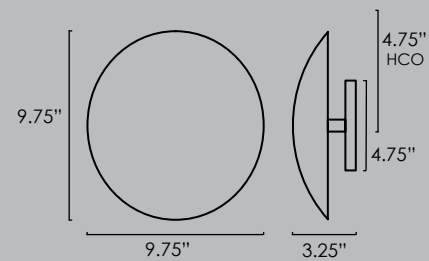

SM81850 • 8" LED Flush Mount

15W LED PCB (integrated)  
 9.75"W x 9.75"H x 3.25"E  
 BP: 4.75"D x 0.75", 4.75"HCO  
 CCT Select 3000-2700-2200K, CRI 90+

Available in Mat White w/ French Gold (MWFG)  
 Black with French Gold (BKFG)  
 French Gold (FG)  
 Polished Chrome (PC)



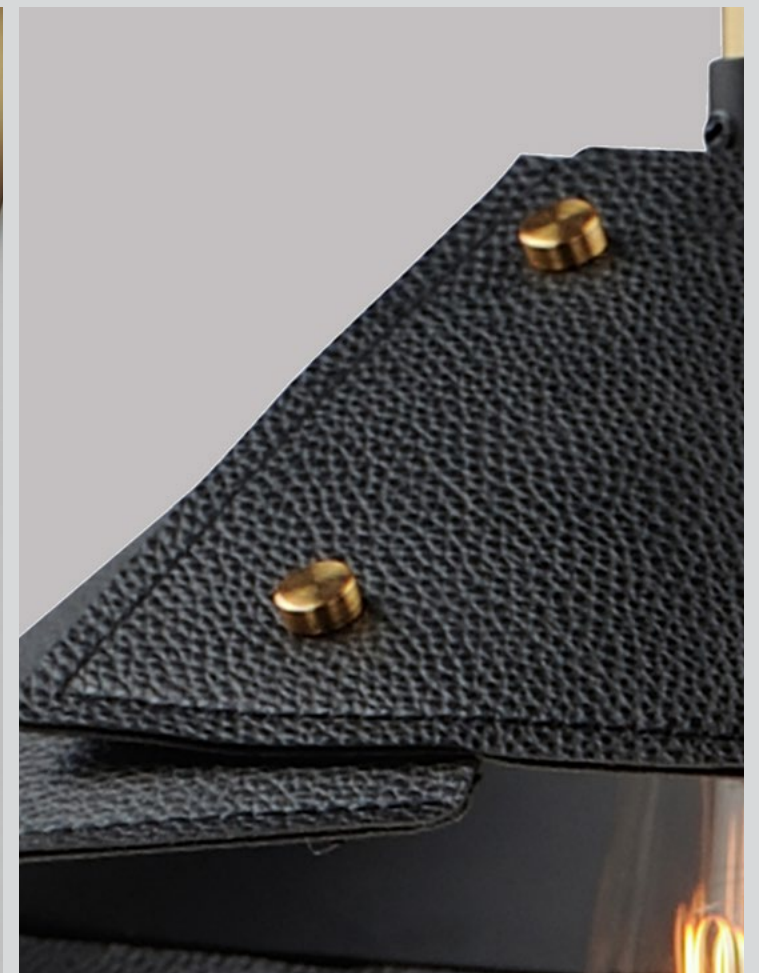

# CAVALIER

Expertly stitched leather shades are bound by brass finials in a folded shape that is radially asymmetric. These black leather shades obstruct LED lamping to create ambient indirect lighting and pair well with the Naturally Aged Brass frames that feature a smooth, chestnut leather wrap detail. The shades on the expansive two-light pendant are adjustable to provide function on its oversized width perfectly chic over a dining table, bar, or kitchen island. The wall sconce option is designed for both portable pin-up mounting or hardwired applications and single pendants are available in two sizes. The Cavalier lighting collection exercises Mat Sanders' talent for understated elegance, where the lighting products stand out in their unassuming details.



SM81804

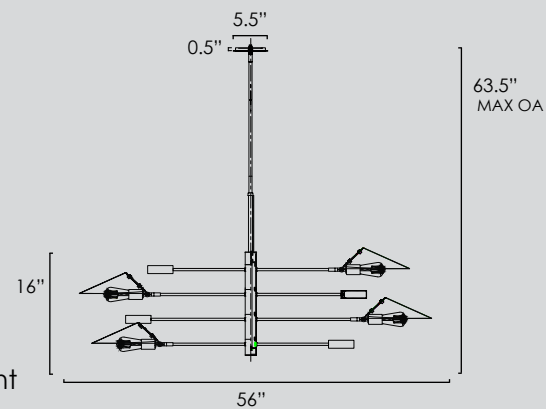

SM81804 • 4LT Pendant

(4) 6W ST58 LED (included)  
 56"D x 20"H x 63.5"Max OA  
 Canopy: 5.5"D x 0.50"H

Available in Black/Dark Leather with  
 Natural Aged Brass (NAB)



SM81802

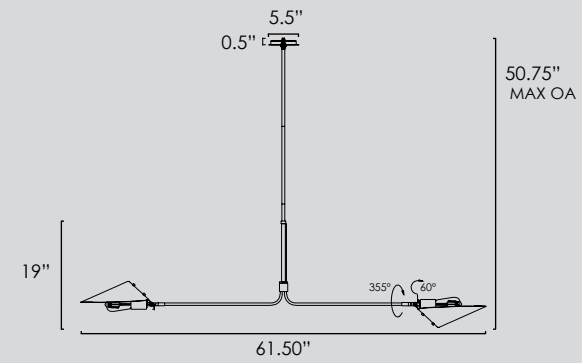

SM81802 • Linear Pendant

(2) 6W ST58 LED (included)  
 9.5"W x 19"H x 61.5"L, 50.75" Max OA  
 Canopy: 5.5"W x 0.5"H  
 2700K, CRI 90+, 900 lm

Available in Black/Dark Leather with  
 Natural Aged Brass (NAB)





SM81801



SM81806



SM81800

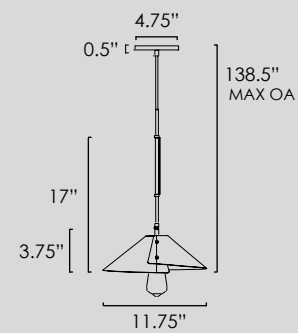

SM81801 • Mini Pendant

(1) 6W ST58 LED (included)  
 11.75"D x 3.75"H, 138.5" Max OH  
 Canopy: 4.75"W x 0.5"H  
 2700K, CRI 90+, 450 lm

Available in Black/Dark Leather with  
 Natural Aged Brass (NAB)

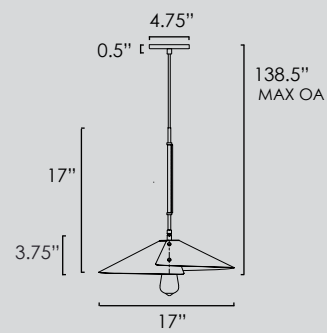

SM81806 • Single Pendant

(1) 6W ST58 LED (included)  
 17"D x 3.5"H x 138.5" Max OA  
 Canopy: 4.75"W x 0.5"H  
 2700K, CRI 90+, 450 lm

Available in Black/Dark Leather with  
 Natural Aged Brass (NAB)

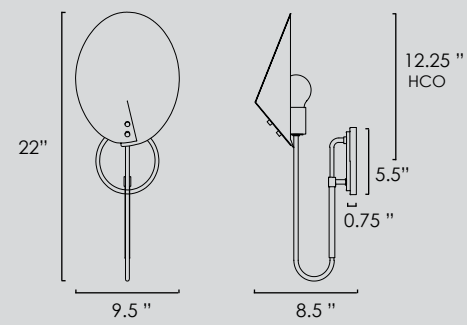

SM81800 • Sconce

(1) 6W ST58 LED (included)  
 9.5"W x 22"H x 8.5"E  
 BP: 5.5"D x 0.75"H, 12.25 HCO  
 2700K, CRI 90+, 450 lm

Available in Black/Dark Leather with  
 Natural Aged Brass (NAB)

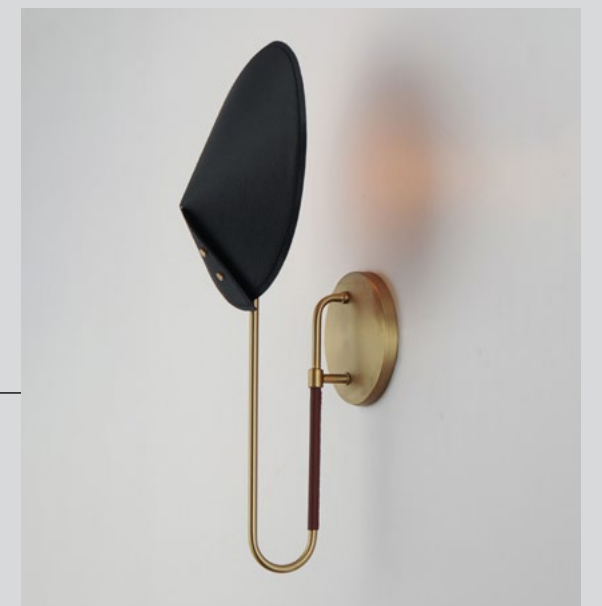





# PRISMATIC

Somewhat recessed within a classic Mid-Century metal shade, a secondary thick glass shade pressed with prismatic patterns casts an iridescent light. The dedicated LED light source is concealed to reduce glare while providing ample lighting. Choose from large, thin-profiled cymbals of Brass with Dark Brown leather accents or Midnight Black metalwork with Black pebbled leather wraps stitched onto the frame. The Prismatic series of pendants, low profile surface mounts, and portable lamps incorporate advanced LED technology. A convenient touch dimmer on the base of the portable lamps features 3-step dimming allowing you to control the light settings for ambient or functional uses.

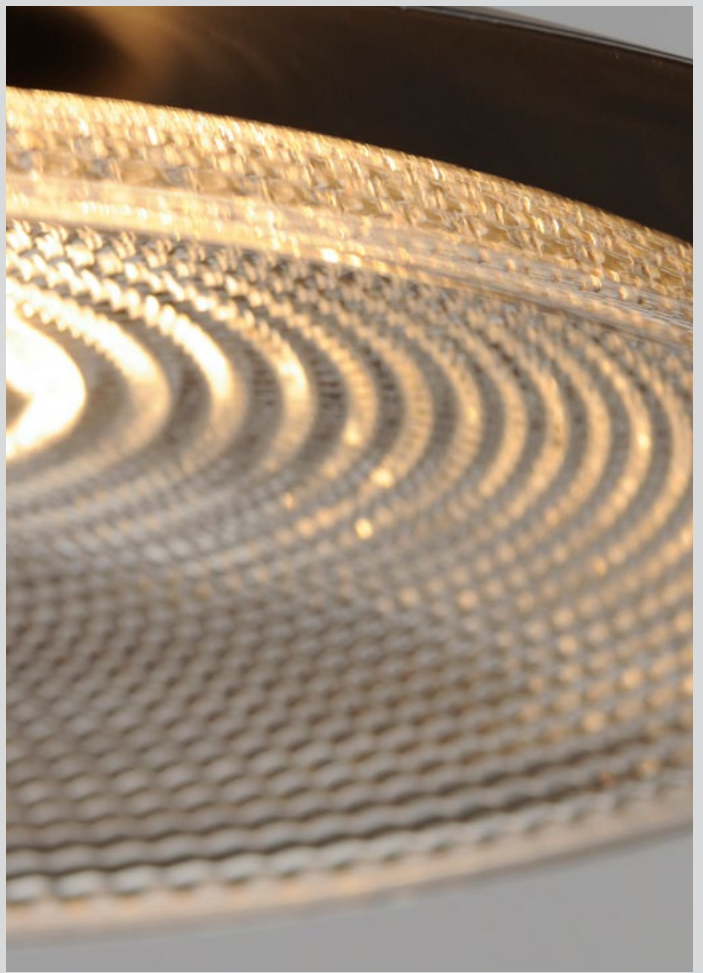
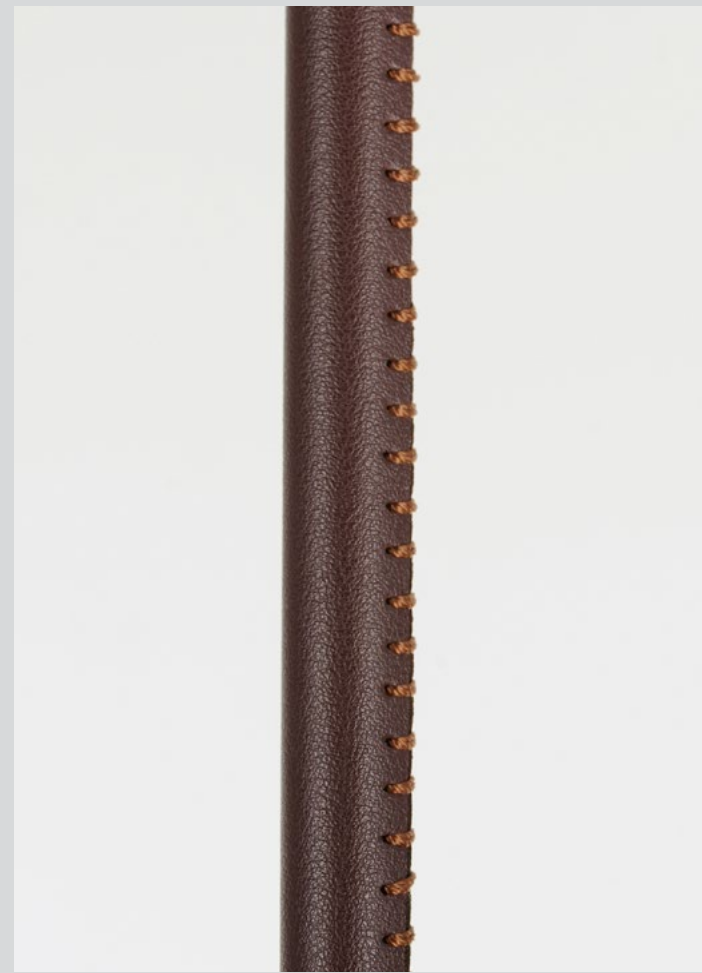
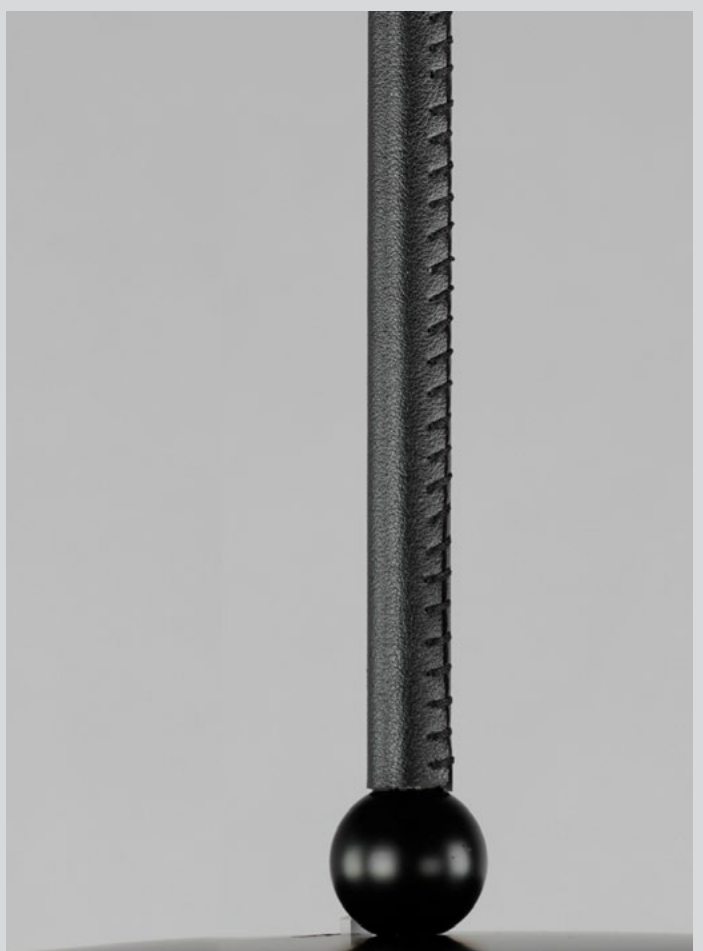

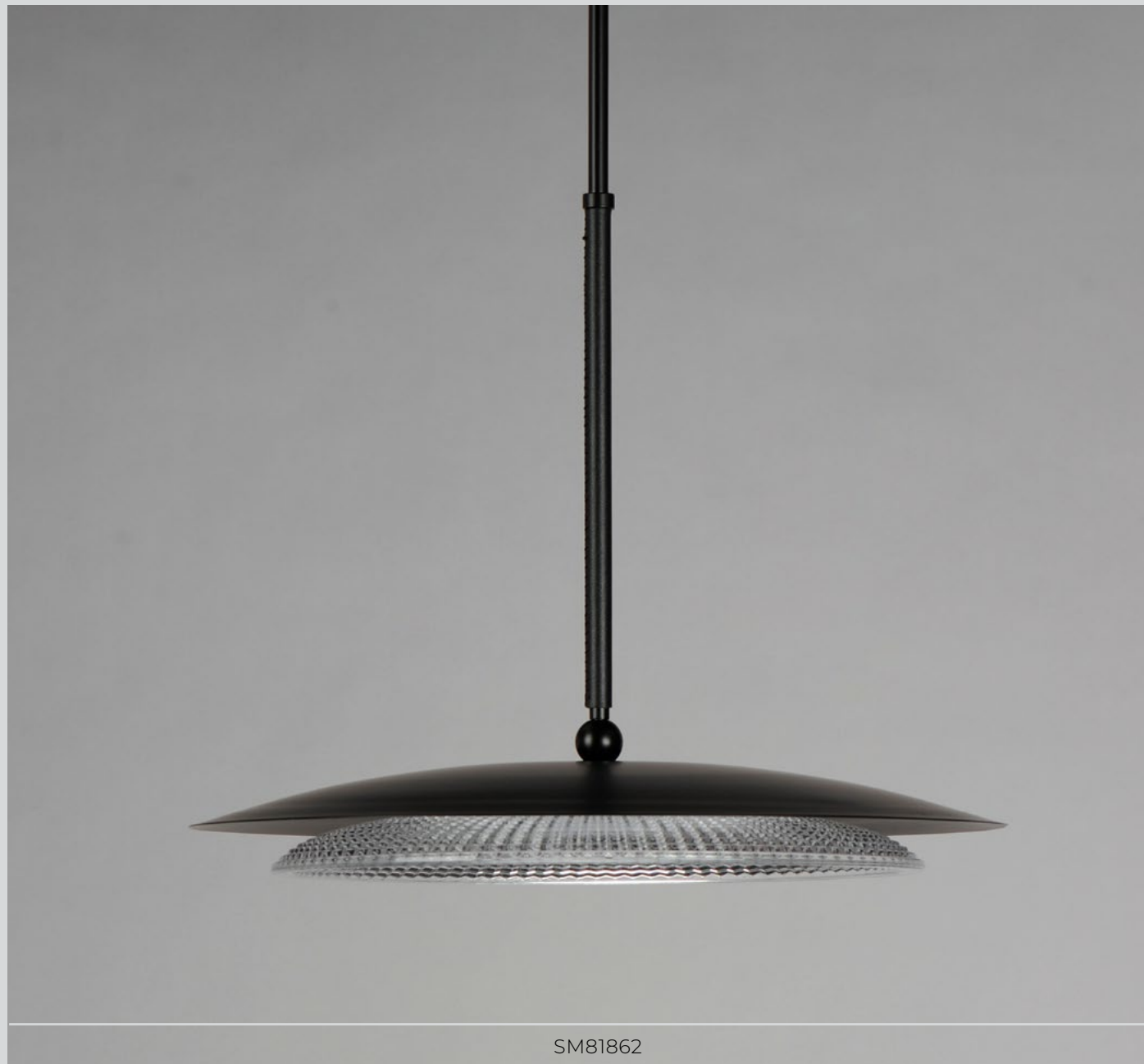

SM81862

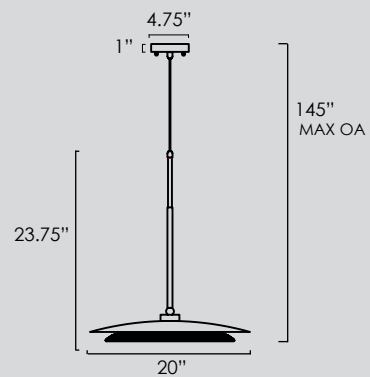

SM81862 • Pendant

15W LED PCB (integrated)  
 20"W x 23.75"H x 20"L, 145"Max OA  
 Canopy: 4.75"W x 1"H  
 CRI 90+, 800 lm  
 3 color select (Warm - White - Cool)

Available in Natural Aged Brass (CRNAB) Black (CRBK)



SM81860 • Wall Sconce / Flush Mount

15W LED PCB (integrated)  
 15.75"D x 4.5"H  
 Backplate: 4.75"W x 1"H, 7.75"HCO  
 CRI 90+, 800 lm  
 3 color select (Warm - White - Cool)

Available in Natural Aged Brass (CRNAB) Black (CRBK)

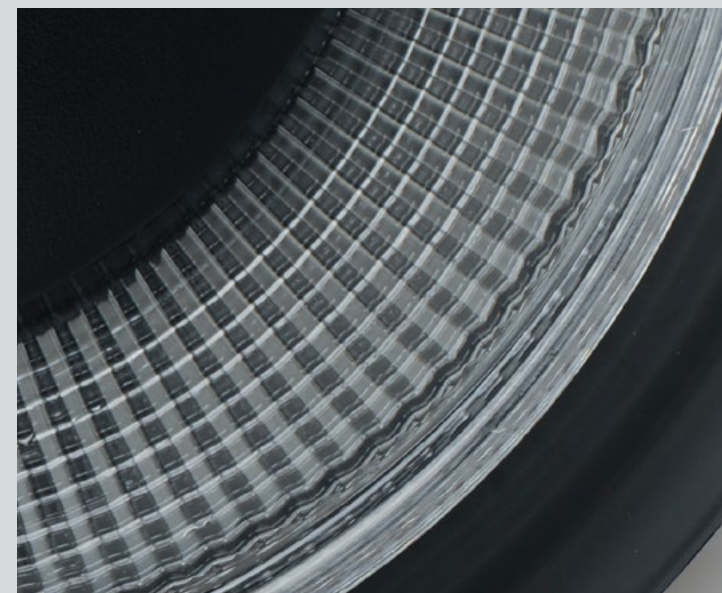



SM81868

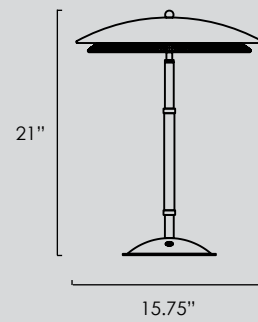
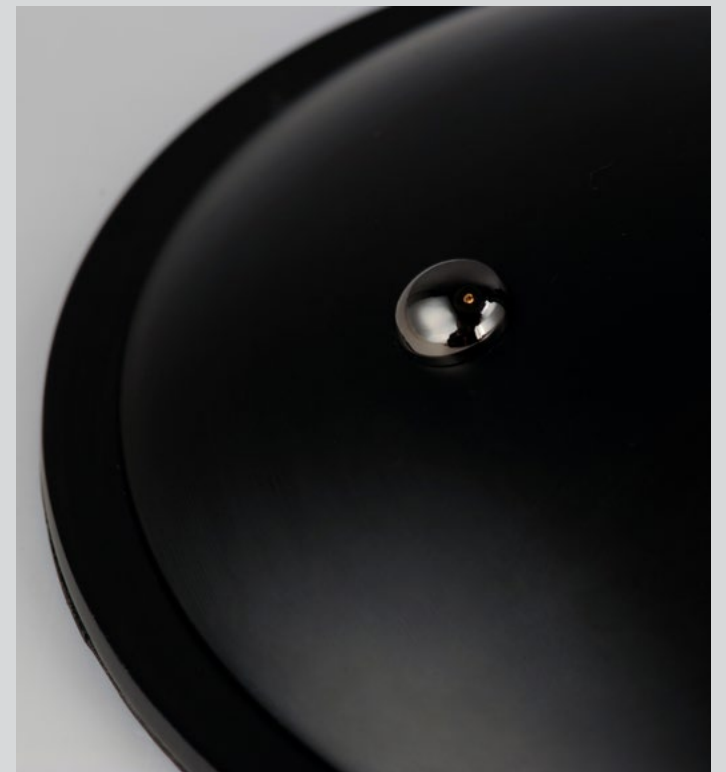

SM81868 • Table Lamp

15W LED PCB (integrated)  
15.75"W x 21"H x 15.75"L  
CRI 90+, 800 lm  
3 color select (Warm - White - Cool)

Available in Natural Aged Brass (CRNAB) Black (CRBK)





# 10 CARAT

Having deconstructed the chandelier, 10 Carat offers formless function with jewel-like crystals suspended by Aluminum lamp holders and fiber cords run through a wire-way constructed of tubing finished in Satin Brass.



SM23781

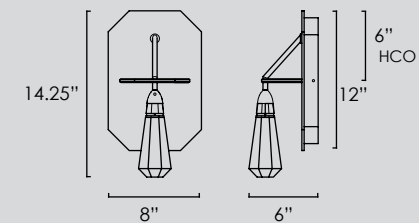

SM23781 • Sconce

3W LED PCB (integrated)  
8"W x 14.25"H x 6"E  
BP: 8"W x 12"H, 6" HCO  
2700K, CRI 80+, 270 lm

Available in Satin Nickel with Satin Brass (BCSNSBR)



SM23783



SM23783 • Single Pendant

3W LED PCB (integrated)  
2.75"D x 7.75"H, 132.25" Max OA  
Canopy: 7.5"D x 6.75"H  
2700K, CRI 80+, 270 lm

Available in Satin Nickel with Satin Brass (BCSNSBR)



SM23785



SM23787

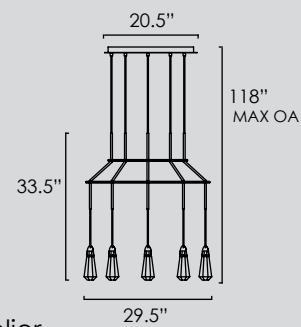

SM23785 • Chandelier

(10) 2.5W LED PCB (integrated)  
 29.5"W x 33.5"H x 29.5"L, 118" Max OA  
 Canopy: 20.5"D x 1"H  
 3000K, CRI 80+, 1750 lm

Available in Satin Nickel with Satin Brass (BCSNSBR)

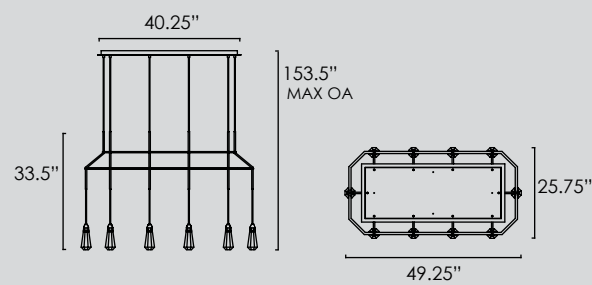

SM23787 • Linear Chandelier

(10) 3W LED PCB (integrated)  
 25.75"W x 33.5"H x 49.25"L, 153.5" Max OA  
 Canopy: 16.5"W x 1.25"H x 40.25"L  
 2700K, CRI 80+, 2700 lm

Available in Satin Nickel with Satin Brass (BCSNSBR)



# TRAPEZE

With a nod to the art and fashion world, the sculptural-art luminaire, Trapeze, showers LED light downward through glistening flat chain links finished in Polished Silver and Gold draped randomly over a Satin Nickel cylindrical bar. The power cord in gold and silver thread complements the fixture's finishes.

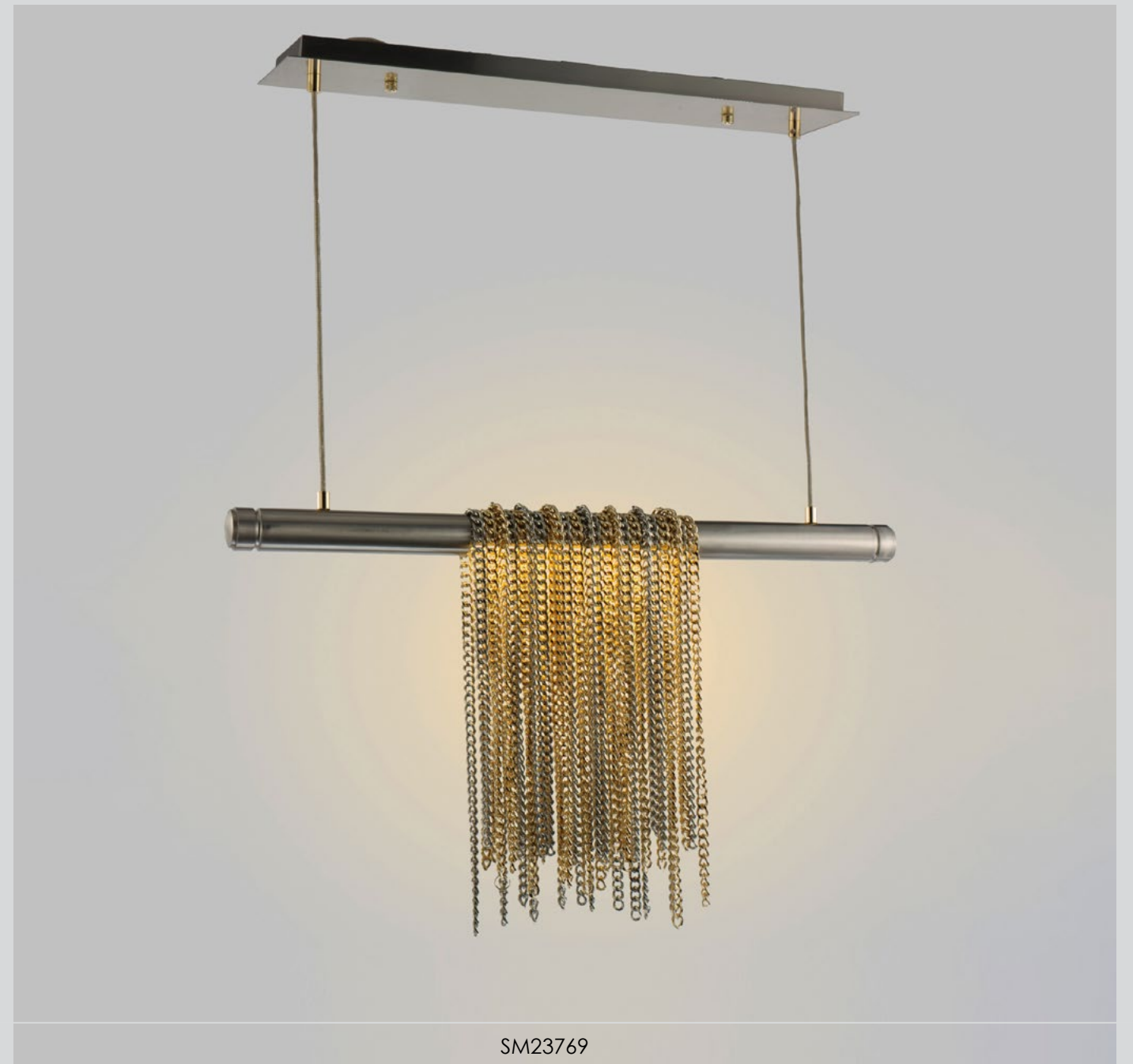

SM23769

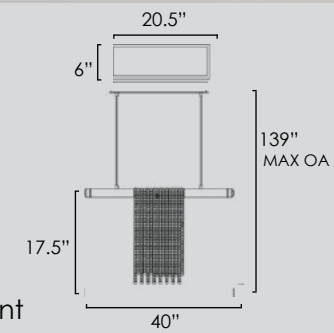

SM23769 • Linear Pendant

32W LED PCB (integrated)  
6"W x 17.5"H x 40"L, 139" MAX OA  
Canopy: 6"W x 1"H x 20.5"L  
3000K, CRI 90+, 1450 lm

Available in Satin Nickel with Polished Gold (SNPG)

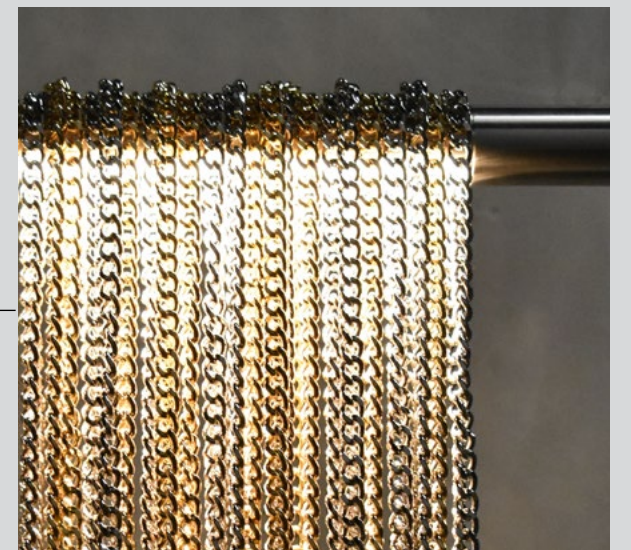

# CRADLE

Natural Rock Crystal and Custom K9 Crystal strands are coalesced skillfully among G4 bulbs curtaining the steel frame while exuding warmth and luxury. Flaunting a gold hand-painted silver leaf finish, the Cradle dazzles magnificently and demonstrates the feasibility of functional beauty.



SM23834

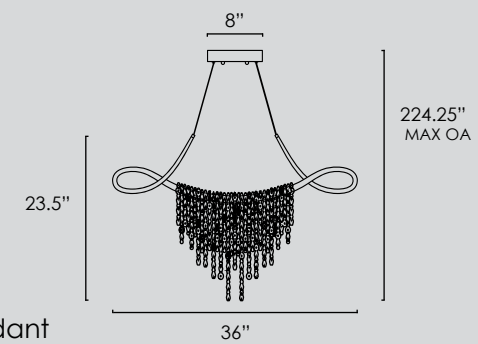

SM23834 • Linear Pendant

(5) 20W Xenon 12V G4 (included)  
4.25"W x 23.5"H x 36"L, 224.25" Max OA  
Canopy: 4.25"W x 1.5"H x 8"L

Available in Gold Silver (GS)





# UNITY XL



SM254713 • 3' Bean Pendant

58W LED DC (integrated)  
 36"W x 1.5"H x 41.25"L, 121" Max OA  
 Canopy: 8.5"D 1.75"H  
 2700K, CRI 90+, 2320 lm



SM254718 • 8' Bean Pendant

93W LED DC (integrated)  
 47.25"W x 1.5"H x 94.25"L, 121" Max OA  
 Canopy: 8.5"D 1.75"H  
 2700K, CRI 90+, 3720 lm



SM254714 • 3.5' Oval Pendant

52W LED DC (integrated)  
 31.25"W x 1.5"H x 42.25"L, 121" Max OA  
 Canopy: 8.5"D 1.75"H  
 2700K, CRI 90+, 2080 lm



SM254717 • 7' Oval Pendant

89W LED DC (integrated)  
 43"W x 1.5"H x 84.5"L, 121" Max OA  
 Canopy: 8.5"D 1.75"H  
 2700K, CRI 90+, 3560 lm





# NORMA JEANE

They say "Diamonds are Girl's Best Friend," and this show-stopping classic renews the glitz and glamour of another time. Satin Brass ringlets form a sphere that houses diamond-like crystal elements illuminated from within by LED technology, transforming this brass globe into a shimmering jewel.



SM23771

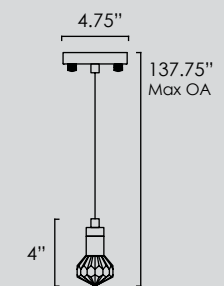

SM23771 • Single Pendant

(1) 2.3W LED G9 (included)  
4.75"W x 4"H, 137.75" Max OA  
Canopy: 4.75"W x 1"H  
3000K, CRI 80+, 200 lm

Available in Satin Brass (BCSBR)



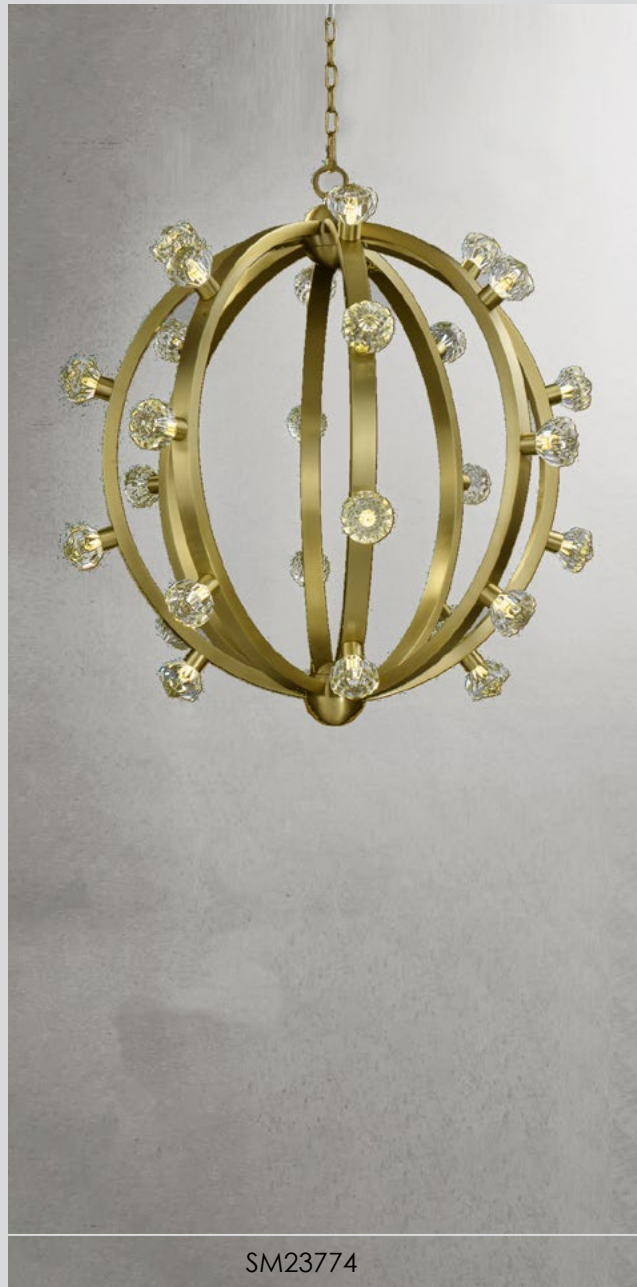

SM23774



SM23776

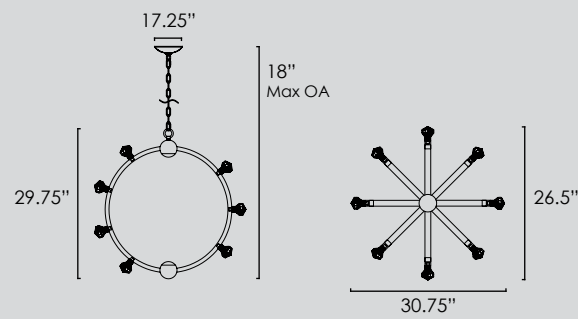

SM23774 • Medium Pendant

(28) 2.3W LED G9 3500K (included)  
 30.75"W x 29.75"H x 30.75"L, 103.75" Max OA  
 Canopy: 5.75"W x 1.5"H  
 CRI 90+, 5320 lm

Available in Satin Brass (BCSBR)

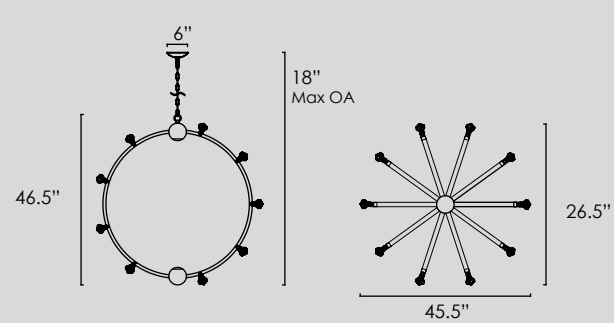

SM23776 • Large Pendant

(45) 2.3W LED G9 3500K (included)  
 45.5"W x 46.5"H x 45.5"L 120.5" Max OA  
 Canopy: 8"W x 2"H  
 CRI 90+, 8550 lm

Available in Satin Brass (BCSBR)

STUDIO • M