

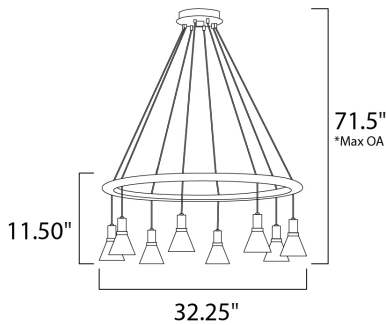

PRODUCT DESCRIPTION

A modern expression using natural materials, Scan features a stained Walnut wood wire way. Clear conical glass is suspended by Black Rayon cord and completed with Polished Nickel metalwork. 40 Watt Xenon G9 bulbs included.



*max overall height of fixture

MEASUREMENTS

DIMENSION : 32.25" L x 32.25" W x 11.5" H
 MAX OAH : 71.5" OAH
 CANOPY : 7.25" W x 1.5" H x 7.25" L
 HANGING WEIGHT : 11.8 lb

LAMPING

INPUT VOLTAGE : 120V
 LUMENS : 3,920 Rated
 BULB : 40W Xenon G9 , 320W Total
 BULB INCLUDED : (Included)
 DIMMABLE : Yes

FINISHES OPTION

 Walnut (WN)

GLASS

Clear CL

MATERIAL

Steel, Wood

RATINGS

cETLus
 Dry Location



ADDITIONAL

ADJUSTABLE
 RATED LIFE 2000 Hours
 OPERATING TEMPERATURE:
 -20°C (-4°F), 40°C (104°F)

Always consult a qualified electrician before installing any lighting product.



Modifications or Customizations: Please email contract@studiomlighting.com
Sample Request: Please email order@studiomlighting.com with subject line "Sample Order_ [Project Name] / [Specifier/Designer]"
 All samples are subject to Studio M approval and must show proof of project and/or explanation.

Job Name:	Job Type:
Quantity:	Comments: