



MAT SANDERS
STUDIO•M

PRODUCT DESCRIPTION

Leather swathes are stitched at their edges and brought together, bound by brass finials, to form shades above brass sockets. Elongated extensions of Naturally Aged Brass tubing are enhanced by smooth, Tobacco Brown leather accents saddle-stitched and wrapped over the frame. The subtle contrast between the brass, bronze, and pebbled black leather shades results in a stately composition that is warm enough for more traditional settings, whereas the asymmetry of the constructed form adds visual interest in their modern configuration. The pebbled black leather shades function to obstruct LED filament lamping to reduce the glare from the industrial lamps while directing the light where needed. An added feature allows you to rotate the shades and adjust their position for more flexibility in the design. Exercising his talent for understated elegance, Mat Sanders designed a statement piece that is unassuming and luxuriant.

FINISHES OPTION

 Natural Aged Brass (NAB)

MATERIAL

Steel, Leather, Aluminum

RATINGS

cETLus
Dry Location



ADDITIONAL

SLOPE: 15
RATED LIFE 25000 Hours
OPERATING TEMPERATURE:
-20°C (-4°F), 40°C (104°F)

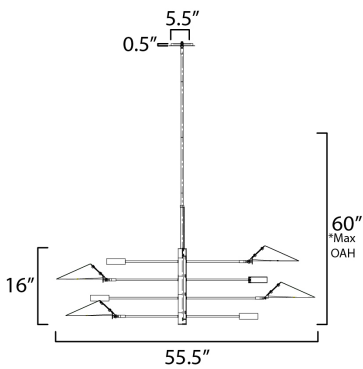

MEASUREMENTS

DIMENSION : 50" L x 50" W x 16" H
MAX OAH : 60" OAH
CANOPY : 5.5" W x 0.5" H x 5.5" L
HANGING WEIGHT : 15.4 lb

LAMPING

INPUT VOLTAGE : 120V
LUMENS : 2,500 Rated (2,100 Del.)
BULB : 6W LED E26 Medium , 24W Total
BULB INCLUDED : (Included)
DIMMABLE : Y
CRI : 90 CRI
COLOR_TEMP : 3000K

Always consult a qualified electrician before installing any lighting product.

STUDIO•M

Modifications or Customizations: Please email contract@studiomlighting.com
Sample Request: Please email order@studiomlighting.com with subject line "Sample Order_ [Project Name] / [Specifier/Designer]"
All samples are subject to Studio M approval and must show proof of project and/or explanation.

Job Name:	Job Type:
Quantity:	Comments: